



An Introduction to Dynamic FE Analysis

September 30th, 2009





Agenda

An Introduction to Dynamic FE Analysis

September 30th, 2009

7am PDT (Seattle) / 10am EDT (New York) / 3pm BST (London)

▲ Welcome & Introduction (Overview of NAFEMS Activities)

▲ Mr. Matthew Ladzinski

▲ An Introduction to Dynamic FE Analysis

▲ Mr. Tony Abbey

▲ Q&A Session

▲ Panel

▲ Closing



Ladzinski



Abbey



THE INTERNATIONAL ASSOCIATION
FOR THE ENGINEERING ANALYSIS
COMMUNITY

An Overview of NAFEMS Activities



Matthew Ladzinski
NAFEMS
NAFEMS North America



Planned Activities

➤ Webinars

- New topic each month!
 - Practical CFD – October 28th, 2009
 - How to Ensure that CFD for Industrial Applications is Fit for Purpose – November 2009
- Recent webinars:
 - Composite FE Analysis
 - 10 Ways to Increase Your Professional Value in the Engineering Industry
 - Dynamic FE Analysis
 - Modal Analysis in Virtual Prototyping and Product Validation
 - Pathways to Future CAE Technologies and their Role in Ambient Intelligent Environments
 - Computational Structural Acoustics: Technology, Trends and Challenges
 - FAM: Advances in Research and Industrial Application of Experimental Mechanics
 - CCOPPS: Power Generation: Engineering Challenges of a Low Carbon Future
 - Practical CFD Analysis
 - Complexity Management
 - CCOPPS: Creep Loading of Pressurized Components – Phenomena and Evaluation
 - Multiphysics Simulation using Implicit Sequential Coupling
 - CCOPPS: Fatigue of Welded Pressure Vessels
 - Applied Element Method as a Practical Tool for Progressive Collapse Analysis of Structures
 - A Common Sense Approach to Stress Analysis and Finite Element Modeling
 - The Interfacing of FEA with Pressure Vessel Design Codes (CCOPPS Project)
 - Multiphysics Simulation using Directly Coupled-Field Element Technology
 - Methods and Technology for the Analysis of Composite Materials
 - Simulation Process Management
 - Simulation-supported Decision Making (Stochastics)
 - Simulation Driven Design (SDD) Findings

To register for upcoming webinars, or to view a past webinar, please visit: www.nafems.org/events/webinars



▲ Established in 2009

▲ Next courses:

▲ Dynamic FE Analysis – October 6th, 2009 (*six-week course*)

▲ Simulation-Supported Engineering: Addressing Variability with Stochastic Simulation – October 28th, 2009 (*four-week course*)

▲ Composite FE Analysis – November 24th, 2009 (*four-week course*)

▲ Proposed course offerings:

▲ Non-linear – January/February 2009 (*four-week course*)







▲ For more information, visit: www.nafems.org/e-learning







NAFEMS Events

Multiple opportunities to attend conferences, seminars/workshops and training courses

Dynamic FE Analysis 6th Oct 2009 Course e-Learning,Online	
Recent Advances in the Fatigue Analysis of Welded Structures 7th Oct 2009 Seminar Gaydon,UK	
FEM Basic 1 - Praxisorientierte Strukturmechanik / Festigkeitslehre 19th Oct 2009 Course Wiesbaden,Germany	
Simulation-Supported Engineering: Addressing Variability with Stochastic Simulation 28th Oct 2009 Course e-Learning,Online	
Multidisziplinäre Simulationen 9th Nov 2009 Seminar Wiesbaden,Germany	
Practical CFD Analysis 11th Nov 2009 Course Wiesbaden,Germany	

FEM Basic 2 - Praxisorientierte Grundlagen für FEM-Analysen 23rd Nov 2009 Course Wiesbaden,Germany	
Introduction au Calcul de Structures, aux Éléments Finis et à la Simulation Numérique 24th Nov 2009 Course Paris,France	
Composites FE Analysis 24th Nov 2009 Course e-Learning,Online	
Practical Stress Analysis & Finite Element Methods 1st Dec 2009 Course Midlands,UK	
Analisi sismica: metodi & applicazioni 2nd Dec 2009 Seminar Bologna,Italy	
Simulating Composite Materials and Structures 2nd Dec 2009 Seminar Esbjerg,Denmark	
Modélisation Système et Réduction de Modèles 3rd Dec 2009 Seminar Paris,France	

Let us know if you would like to schedule an on-site training course

For more information, please visit: www.nafems.org

Welcome and Agenda

Overview of the e-Learning Course

Introductory Dynamic FE Analysis

Q and A

Introduction to FE Training



Primary Skill Set:
NASTRAN
PATRAN
FEMAP

Tony Abbey

BSc Aero. Eng. University of Hertfordshire, UK
MSc Struct. Eng. Imperial College, London

- Started at BAC Warton, UK in 1976
- Worked in UK Defence Industry for 20 years; Hunting Engineering, BAe Systems, RRA
- Joined MSC.Software as UK support and Training Manager in 1996
- Transferred to MSC.Software US in 2000
- Joined Noran Engineering 2003
- Formed FE Training in 2007

e-LEARNING



Members Price: £243 | €264 | \$350

Non-Members Price: £382 | €415 | \$550

Order Ref:el-004

Event Type:Course

Location: E-Learning,Online

Date: Oct 6th to Nov 17th , 2009

www.nafems.org/events/nafems/2009/e-dynamicfea/

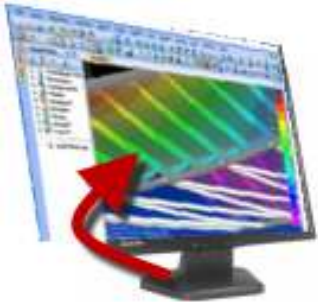

Overview of Dynamics e-Learning Class

Dynamics Analysis

Many problems facing designers and engineers are dynamic in nature. The response of a structure cannot be simply assessed using static assumptions. The nature of the problem may be to understand the resonant frequencies of your design, so that key driving frequencies such as equipment rotational speed, acoustic or external pressure frequencies, ground motion frequency content or vehicle passing frequency.

Your design may face external driving forces from adjacent components; cams, push rods, pistons or from vehicle input sources such as a bumpy road, wave loading, air pressure or inertial forces.

Whatever the nature of the challenge, this objective of this course is to break down the dynamic problem into clearly defined steps, give an overview of the physics involved and show how to successfully implement practical solutions using Finite Element Analysis.



Overview of Dynamics e-Learning Class

Why an e-learning class?

In the current climate travel and training budgets are tight. To help you still meet your training needs the following e-learning course has been developed to complement the live class.

The e-learning course runs over a six week period with a single two hour session per week.

Bulletin Boards and Email are used to keep in contact between sessions, mentoring homework and allowing interchange between students.

E-learning classes are ideal for companies with a group of engineers requiring training. E-learning classes can be provided to suit your needs and timescale. Contact us to discuss your requirements.

We hope that small companies or individuals can now take part in the training experience.

Introductory Dynamic FE Analysis Webinar

Agenda

What are Natural Frequencies, Normal Modes

- and why are they important?

Why can't I get displacements out of Normal Modes Analysis?

- are these 'real' values?

Importance of Mode Identification

- don't just quote a frequency!

What are Rigid Body Modes?

- my structure is elastic, why do I see them?

Introductory Dynamic FE Analysis Webinar

Agenda (continued)

Damping

What level of damping should I use?

Transient Analysis background

– that looks simple, stepping through time?

Frequency Response Analysis

– how is that different from transient analysis?

Quick peek at Shock Spectra and Random analysis

What are Natural Frequencies, Normal Modes

- and why are they important?

Analysis of the Normal Modes or Natural Frequencies of a structure is a search for its **resonant frequencies**.

- A diving board vibrating after the diver makes his leap
- A car cup holder rattling after we go over a bump

We tend to use both terms to mean the resonant frequency of oscillation , but more accurately:

Natural Frequency - the actual measure of frequency in cycles per second (Hz) or similar units

Normal Mode - the characteristic deflected shape of the structure as it resonates – imagine using a strobe to ‘freeze’ motion

There are many resonant frequencies in a typical structure

What are Natural Frequencies, Normal Modes

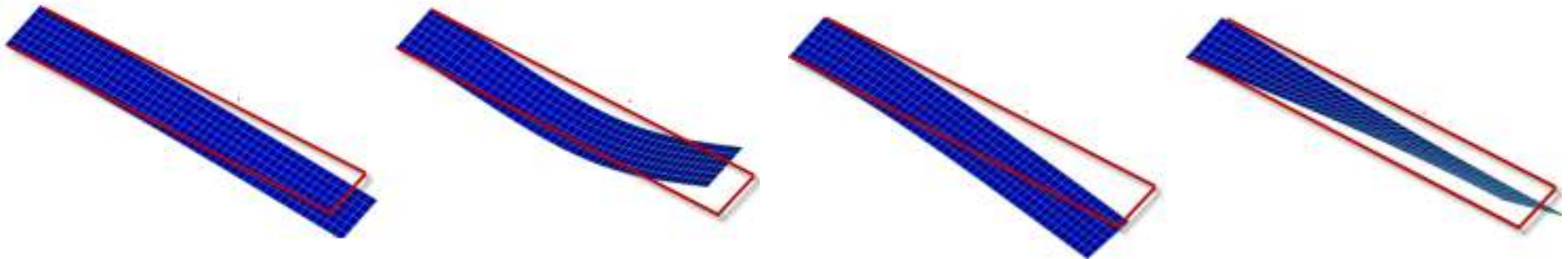

Here are the first 4 modes of the board:

1	First Bending	1.3 Hz
2	Second Bending	3.6 Hz
3	Side Shear	14.5 Hz
4	First Torsion	19.1 Hz

- We expect mode 1 to dominate intuitively, but notice we have a twisting mode— maybe a very heavy ‘athlete’ could just catch a corner of the board and put some twist in?
- How could mode 2 get excited?
- Is mode 3 of any practical interest?

What are Natural Frequencies, Normal Modes

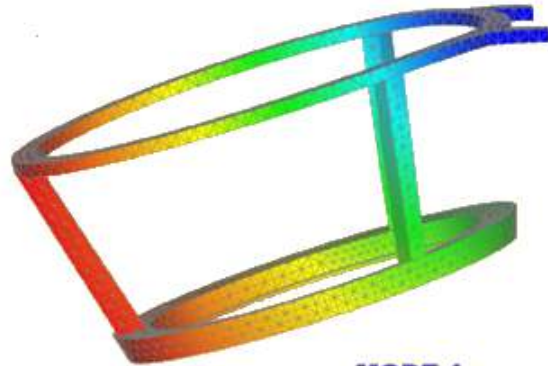

MODE 1

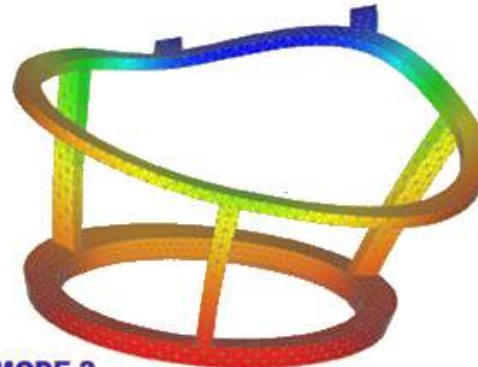

MODE 2

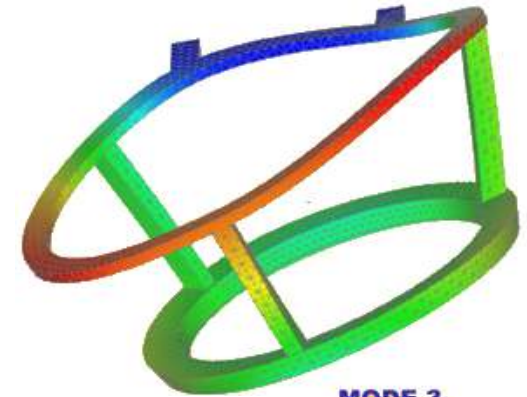

MODE 3

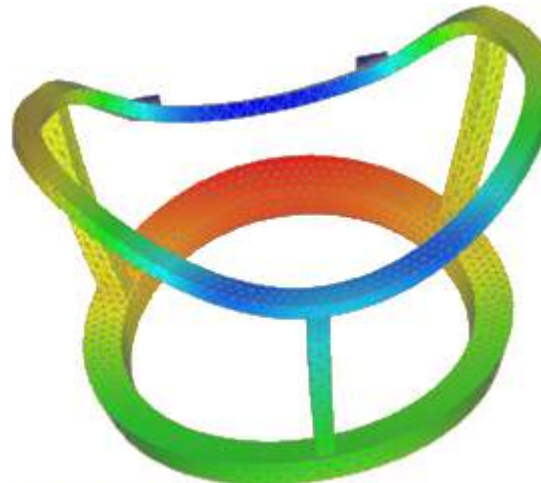

MODE 4

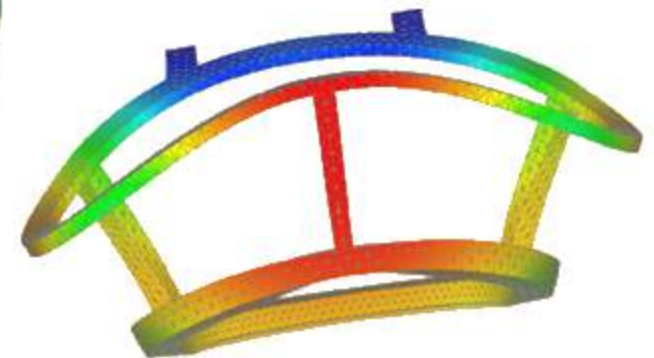

MODE 5

What are Natural Frequencies, Normal Modes

First 5 modes of the cup holder

- The first mode is a cantilever nodding mode, at 15.7 Hz - almost certainly a dominant mode
- Then two twisting modes, at 34.6 Hz and 45.8 Hz
- Then two hogging modes at 124.7 Hz and 144.7 Hz.

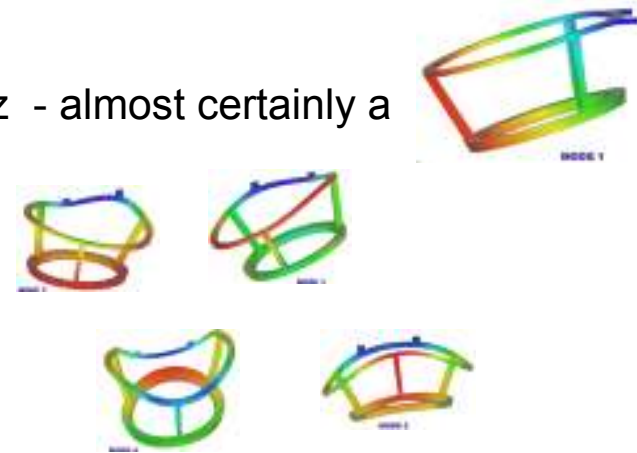

Intuitively we would expect all these to be important modes, but as yet we can't prove that.

The next range of modes are 160 Hz and above and are very complex shapes.

Important question ; what is the range of input or *driving* frequencies? That will dictate which modes are critical.

What are Natural Frequencies, Normal Modes

Assume we are a subcontractor to the auto manufacturer. If we are very lucky he will tell us the range of frequencies we can expect to see at the attachment region on the dashboard, based on his analysis and test results

We can use that as the basis of the range of interest. We can't use the range directly as that ignores the very complex interaction we may see between harmonics of the system and other factors. So we typically take **an upper bound of 1.5 or 2 times** the upper frequency.

The lower bound should go right down to the lowest frequency we find, as it is difficult to provide a sensible cut off here.

So that gives us a set of modes of interest to investigate. We know a lot about the dynamic characteristics of the cup now. The basic **building block** approach.

Next stage is to look at how the cup is excited by the dashboard – the **response** analysis

It could be an actual time history, frequency response, shock spectra or random response at the interface

What are Natural Frequencies, Normal Modes

Frequency Ranges

Theoretically there are an infinite number of natural frequencies in any structure.

- In FE analysis this reduces to the number of degrees of freedom (DOF) in the model.
- We are normally only interested in the dominant frequencies of a system, luckily for us these are *usually* the first few natural frequencies
- Energy required to get a significant response increases as frequency increases

Bridge – say .5 Hz to 5 Hz important. Above 20 Hz effectively ignores excitation

However – excitation frequency may be very high and drives the structural response

Crankshaft in a F1 racing car - say 60,000 RPM – means 1000 Hz is critical

What are Natural Frequencies, Normal Modes

Theoretical Normal Modes analysis is a rather strange process in some ways.

- In practice a structure cannot reveal what natural frequencies it has until we jolt it or hit it or excite it in some way.
- As usual in physics we have to apply an input to the system to get a response out.
- **Physical testing** for normal modes takes this approach

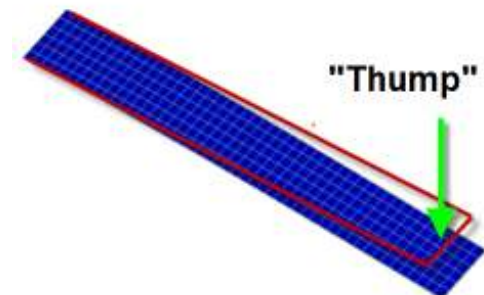
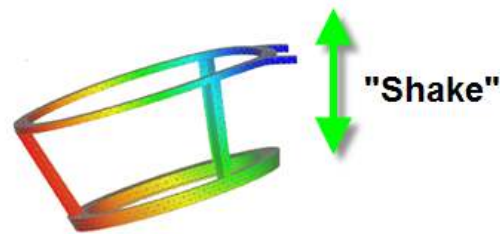

For **Theoretical analysis** we take a different route:

What are Natural Frequencies, Normal Modes

In the theoretical approach we look for all the frequencies of a system that show a **perfect balance** between:

- the internal stored energy
- kinetic energy due to motion

At these frequencies the interchange between the two forms of energy is very easily triggered by any external input which has the same driving frequency.

These 'unique' or 'special' frequencies were labeled **Eigen** Frequencies in the early 20th Century, from the German word. Mode shapes are correspondingly called Eigen Vectors

In the theoretical solution we don't need an external excitation!

The energy balance is calculated by considering the inertial and stiffness terms in isolation. We can find all the structural frequencies and mode shapes this way.

What are Natural Frequencies, Normal Modes

- m = mass (inertia)
- b = damping (energy dissipation)
- k = stiffness (restoring force)
- p = applied force
- u = displacement of mass
- \dot{u} = velocity of mass
- \ddot{u} = acceleration of mass

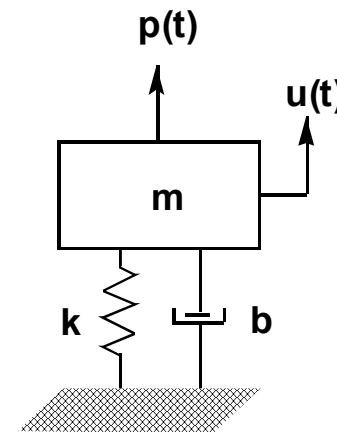

responses \dot{u} and \ddot{u} vary in time

load input p can vary in time

m , k and b are constant with time in linear analysis

What are Natural Frequencies, Normal Modes

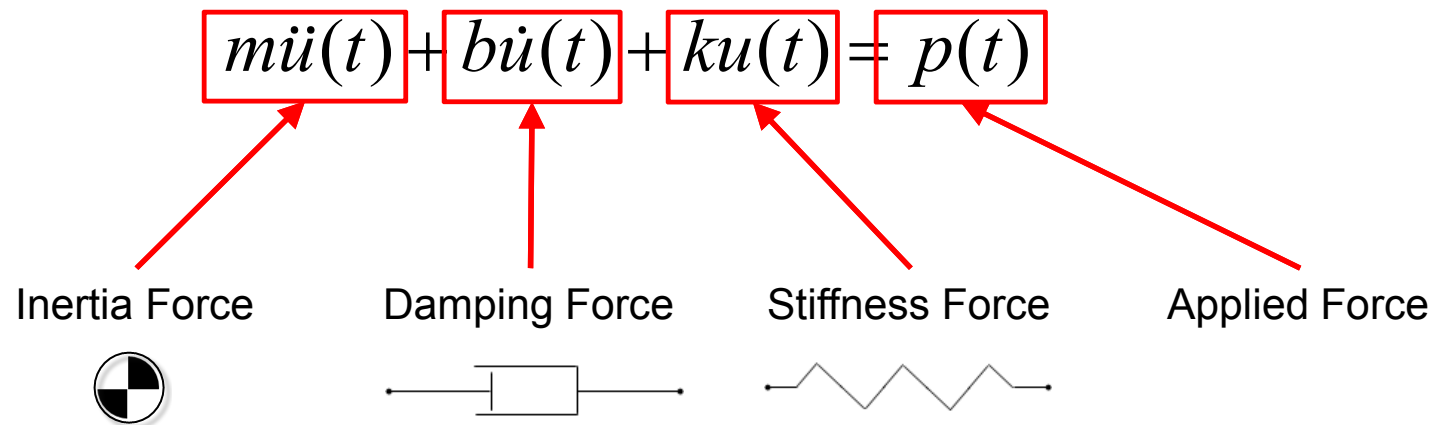

What are Natural Frequencies, Normal Modes

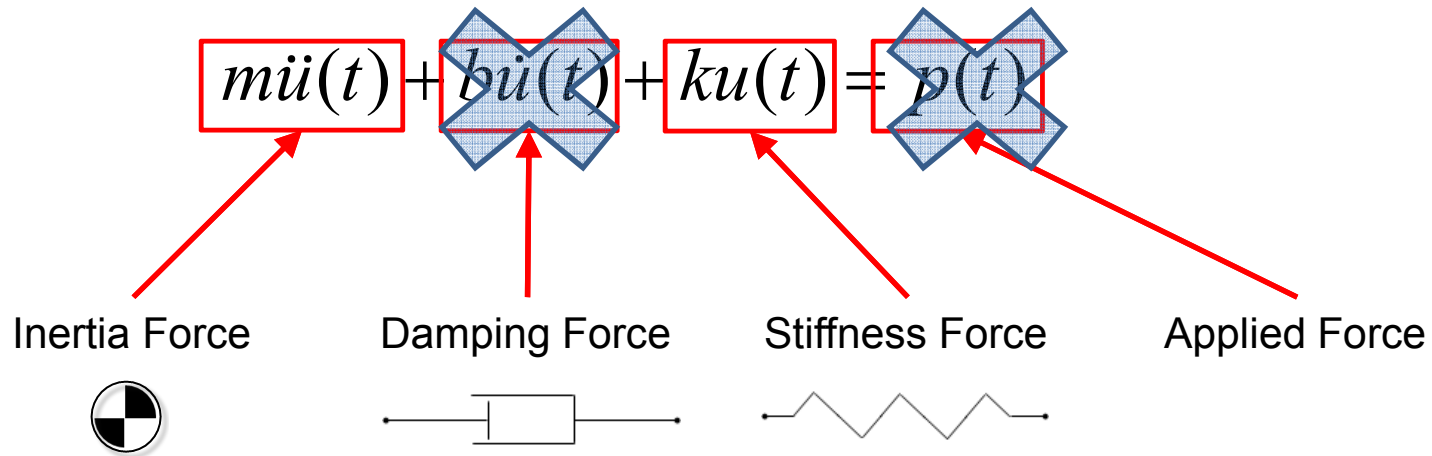

undamped free vibration analysis

What are Natural Frequencies, Normal Modes

In the SDOF equation of motion reduces to:

$$m\ddot{u}(t) + ku(t) = 0$$

Assume a solution of the form:

$$u(t) = A \sin \omega_n t + B \cos \omega_n t$$

This form defines the response as being **HARMONIC**, combinations of sine and cosine shape responses with a resonant frequency of:

$$\omega_n$$

What are Natural Frequencies, Normal Modes

For a SDOF system the resonant, or natural frequency, is given by :

$$\omega_n = \sqrt{\frac{k}{m}}$$

We can solve for the constants A and B :

When $t = 0$, $\sin(\omega_n t) = 0$ thus $B = u(t = 0)$

Differentiating solution :

$$\dot{u}(t) = A\omega_n \cos \omega_n t - B\omega_n \sin \omega_n t$$

When $t = 0$, $B\omega_n \sin(\omega_n t) = 0$ thus

$$A = \frac{\dot{u}(t = 0)}{\omega_n}$$

$$u(t) = \frac{\dot{u}(0)}{\omega_n} \sin \omega_n t + u(0) \cos \omega_n t$$

What are Natural Frequencies, Normal Modes

For a SDOF we know the Natural Frequency or Eigen Value:

:

$$\lambda_n = \frac{k}{m} = \omega_n^2$$

The displacement response is indeterminate as we don't know any initial conditions

$$u(t) = \frac{\dot{u}(0)}{\omega_n} \sin \omega_n t + u(0) \cos \omega_n t$$

The Eigen Vector ϕ_n in this SDOF is literally any arbitrary number

What are Natural Frequencies, Normal Modes

- Now consider the system in terms of a Matrix Solution

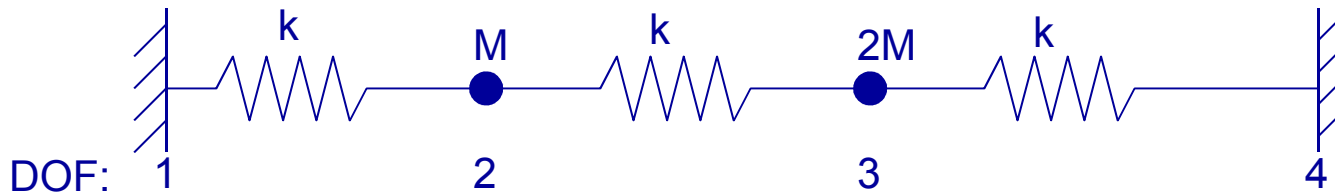

- The individual 'element' stiffness matrices $[K_1]$, $[K_2]$, and $[K_3]$ are:

$$[K_1] = [K_2] = [K_3] = k \begin{bmatrix} 1 & -1 \\ -1 & 1 \end{bmatrix}$$

What are Natural Frequencies, Normal Modes

- To derive the model stiffness matrix $[K]$, we assemble the individual 'element' stiffness matrices $[K_1]$, $[K_2]$, and $[K_3]$:

DOF: 1 2 3 4

$$[K] = k \begin{bmatrix} 1 & -1 & & \\ -1 & 1+1 & -1 & \\ & -1 & 1+1 & -1 \\ & & -1 & 1 \end{bmatrix}$$

- If we eliminate grounded DOF at 1 and 4:

$$[K] = k \begin{bmatrix} 2 & -1 \\ -1 & 2 \end{bmatrix} \quad \text{and} \quad [M] = m \begin{bmatrix} 1 & 0 \\ 0 & 2 \end{bmatrix}$$

We 'lump' masses at DOF

What are Natural Frequencies, Normal Modes

- The equation of motion in matrix form is:

$$[M]\{\ddot{x}\} + [K]\{x\} = 0$$

- If we substitute in

$$\{x\} = \{\phi\}e^{i\omega t}$$

- And $\{\ddot{x}\} = -\omega^2\{\phi\}e^{i\omega t}$

This means we have a mode shape, $\{\phi\}$, which varies sinusoidally with a frequency ω .

- Then $-\omega^2[M]\{\phi\} + [K]\{\phi\} = 0$

This means we can find a mode shape, $\{\phi\}$, and frequency ω where the inertia terms and elastic terms balance

- So $([K] - \omega^2[M])\{\phi\} = 0$

$$\left(k \begin{bmatrix} 2 & -1 \\ -1 & 2 \end{bmatrix} - \omega^2 m \begin{bmatrix} 1 & 0 \\ 0 & 2 \end{bmatrix} \right) \{\phi\} = 0$$

The Eigenvalue problem

What are Natural Frequencies, Normal Modes

- If we have a set of **n** physical degrees of freedom (2 in our case)
 - ❖ Then we have **n** sets of unique Eigenvalues ω_i^2 and eigenvectors $\{\phi\}$
 - where $i = 1$ to n
 - ❖ For each of these sets, the inertia terms balance the elastic terms and this is the definition of resonance

What are Natural Frequencies, Normal Modes

□ So at $\omega_1 = \sqrt{0.634 \frac{k}{m}}$, the motion is defined by: $\{\phi_1\} = \begin{Bmatrix} 0.731 \\ 1.000 \end{Bmatrix}$

□ And at $\omega_2 = \sqrt{2.366 \frac{k}{m}}$, the motion is defined by: $\{\phi_2\} = \begin{Bmatrix} -2.731 \\ 1.000 \end{Bmatrix}$

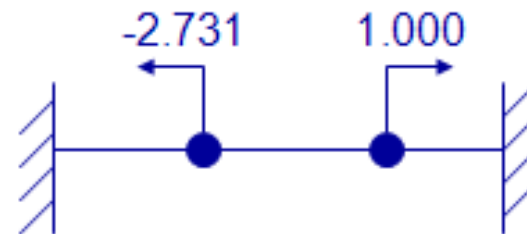
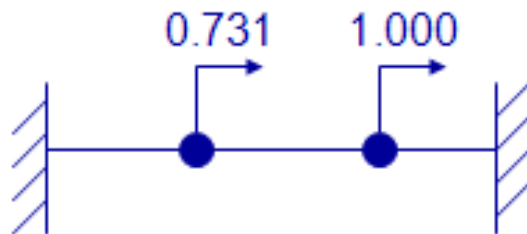

What are Natural Frequencies, Normal Modes

□ Let us add some values in and check out the numbers:

- ❖ Let $k = 1000$ units of force / length
- ❖ Let $m = 20$ units of mass

□ Then
$$\omega_1 = \sqrt{0.634 \frac{k}{m}} = 5.629 \text{ rads/s} = 0.896 \text{ Hz}$$

$$\omega_2 = \sqrt{2.366 \frac{k}{m}} = 10.875 \text{ rads/s} = 1.731 \text{ Hz}$$

- ❖ Notice the conversion of Frequency from Radians/s to Cycles/s (Hertz)

$$\omega = \frac{f}{2\pi}$$

What are Natural Frequencies, Normal Modes



Class Topics taking this further

- Eigenvalue Extraction Methods
- Error Checks in Normal Modes
- Reduction techniques
- Residual Vectors
- Modal Effective Mass
- Case Studies

Introductory Dynamic FE Analysis Webinar

Agenda

What are Natural Frequencies, Normal Modes
- and why are they important?

Why can't I get displacements out of Normal Modes Analysis?
- are these 'real' values?

Importance of Mode Identification
- don't just quote a frequency!

What are Rigid Body Modes?
- my structure is elastic, why do I see them?

Displacements out of Normal Modes Analysis

- are these 'real' values?

In life, sadly we can never get something for nothing.

- The side effect of the Eigen Value method is that we do not know the actual amplitude of the shapes that we calculate.
- This confuses many users who are new to modal analysis.

The 2 DOF spring example gave us

$$\{\phi_1\} = \begin{Bmatrix} 0.731 \\ 1.000 \end{Bmatrix} \quad \{\phi_2\} = \begin{Bmatrix} -2.731 \\ 1.000 \end{Bmatrix}$$

We can equally say:

$$\{\phi_1\} = \begin{Bmatrix} 0.731 \\ 1.000 \end{Bmatrix} \quad \{\phi_2\} = \begin{Bmatrix} 1.000 \\ -0.366 \end{Bmatrix}$$

Displacements out of Normal Modes Analysis

How can we predict a shape without knowing its magnitude?

The simple answer is because we haven't provided any excitation input or initial conditions.

- We don't know the weight of the diver or how high his spring was.
- We don't know the speed of the car or the height of the bump.

All we know is what the range of natural frequencies of the board and the holder will be and what their respective deflected shapes will look like.

But I see screen animations, they must have a value for deformation and they look big?

The answer here is that we scale the magnitude of the shapes to one of several types of arbitrary definitions for convenience and for shape comparison.

A post processor will further scale deformations so you can see each mode shape clearly – typically 10% of the maximum viewable dimension, again quite arbitrary.

The second part of the question is very important – we are only dealing with linear, small displacement theory. So in practice vibration amplitudes would have to be small relative to the size of the structure.

Displacements out of Normal Modes Analysis



Class Topics taking this further

- Pseudo static assumptions
- Modal Effective mass in base motion

Introductory Dynamic FE Analysis Webinar

Agenda

What are Natural Frequencies, Normal Modes
- and why are they important?

Why can't I get displacements out of Normal Modes Analysis?
- are these 'real' values?

Importance of Mode Identification
– don't just quote a frequency!

What are Rigid Body Modes?
– my structure is elastic, why do I see them?

Importance of Mode Identification

– don't just quote a frequency!



2144 Hz !!!

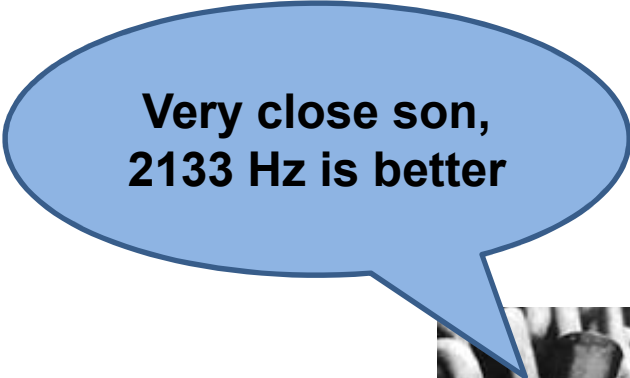

Very close son,
2133 Hz is better

0.5% error here?



Importance of Mode Identification

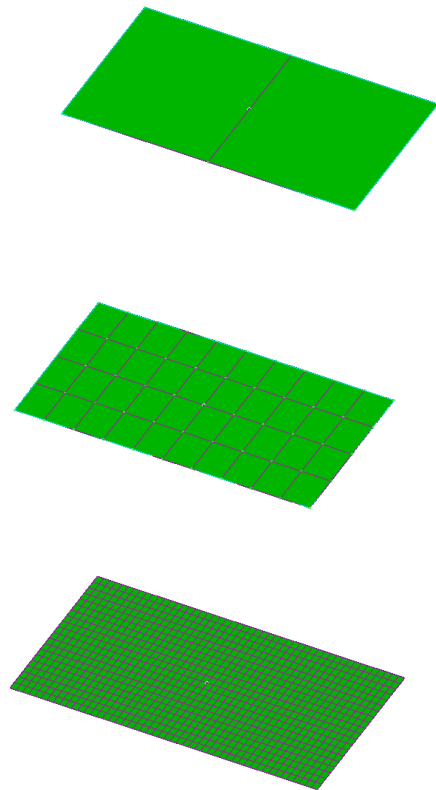

Mode	<i>f</i>	Mesh 1b (2 x 1) Description	Mode	<i>f</i>	Mesh 1a (10 x 4) Description	Mode	<i>f</i>	Mesh 1c (50 x 20) Description
1	120.1	1 st Order Bending	1	133.1	1 st order Bending	1	133.6	1 st order Bending
2	395.7	1 st Order Torsion	2	348.7	1 st Order Torsion	2	689.6	1 st Order Torsion
3	624.5	2 nd Order Bending	3	821.4	2 nd Order Bending	3	832.8	2 nd Order Bending
4	1003	2 nd Order Torsion	4	2043	2 nd Order Torsion	4	2133	2 nd Order Torsion
5	2144	1 st Order Shear	5	2278	3 rd Order Bending	5	2332	3 rd Order Bending
6	8722	2 nd Order Shear	6	2358	1 st Order Shear	6	2358	1 st Order Shear
7	9988	1 st Order Extension	7	3705	3 rd Order Torsion	7	4051	3 rd Order Torsion
8	16667	2 nd Order Shear II	8	4344	4 th Order Bending	8	4552	4 th Order Bending
9	20793	2 nd Order Extension	9	4763	1 st Order Axial Bending	9	5633	1 st Order Axial Bending
10	22799	2 nd Order Shear III	10	5569	2 nd Order Axial Bending	10	6433	4 th Order Torsion

Importance of Mode Identification

Correlation between models and model and test is important

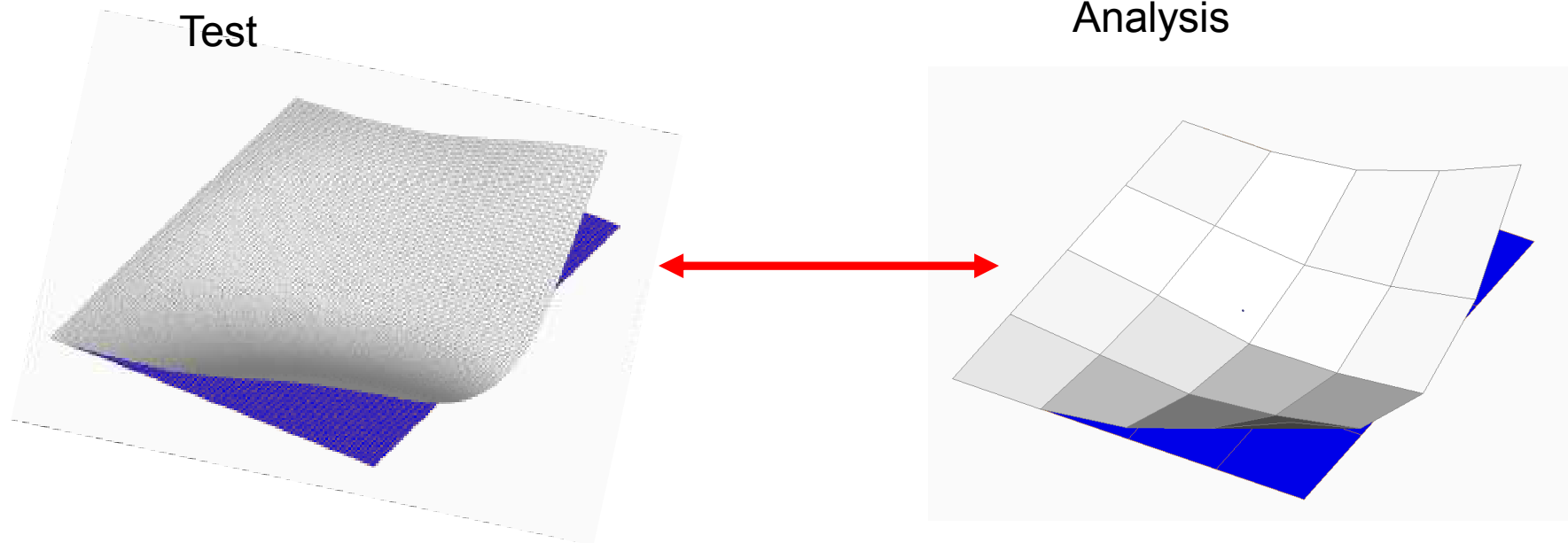

Corresponding points on test and analysis model are located and deflections measured, for each mode shape found

Importance of Mode Identification

Mass Normalised Eigenvectors within one system have the characteristic:

$$\{\Phi\}_i^T [M] \{\Phi\}_i = 1.0$$

$$\{\Phi\}_i^T [M] \{\Phi\}_j = 0.0$$

Consider Mass Normalised Eigenvectors across two systems

$\{\Phi\}_A$ Refers to the Analysis Results

$\{\Phi\}_T$ Refers to the Test or External Model Results

Importance of Mode Identification

Mass Orthogonality Check is

$$\text{Diagonal} \quad \{\Phi\}_A^T [M] \{\Phi\}_T = 1.0$$

for perfect correlation

$$\text{Off-Diagonal} \quad \{\Phi\}_A^T [M] \{\Phi\}_T = 0.0$$

A perfectly correlated Analysis and Test result will be a Unit Diagonal Matrix

Closeness to 1.0 or 0.0 represents degree of orthogonality

It is the ratio between the diagonal and off diagonal terms which is important

Importance of Mode Identification

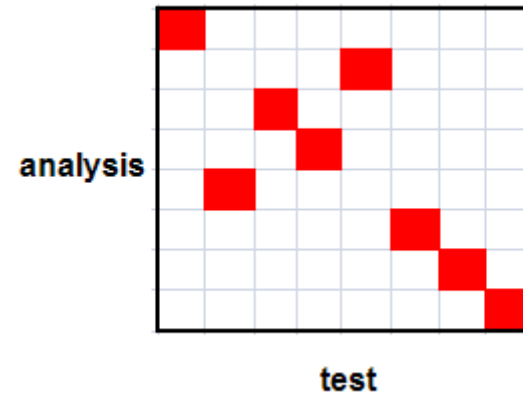
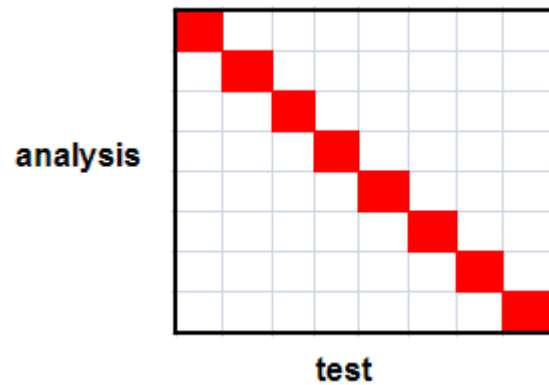
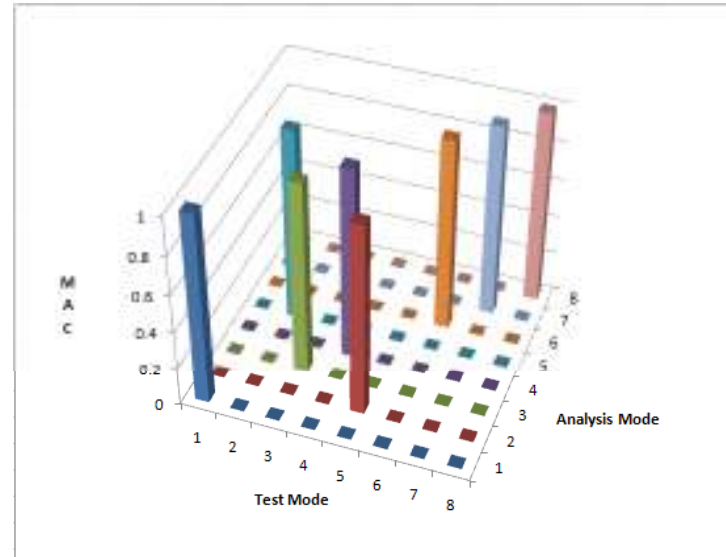
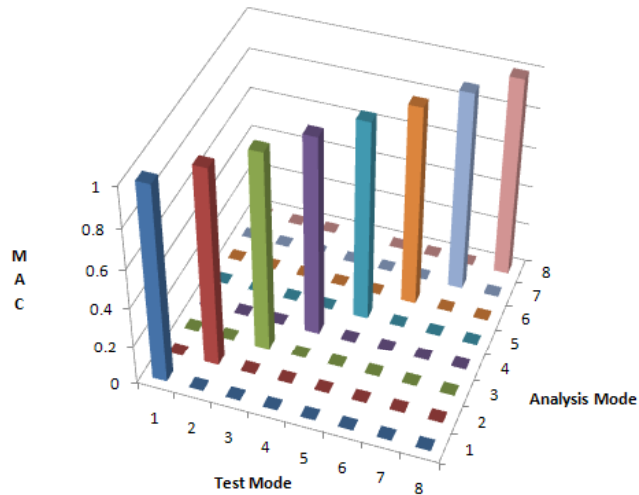

Importance of Mode Identification

Modal Assurance Criteria (MAC) has a similar approach

$$\frac{\left[\{\Phi\}_A^T \{\Phi\}_T \right]^2}{\{\Phi\}_A^T \{\Phi\}_T \times \{\Phi\}_T^T \{\Phi\}_A}$$

A perfectly correlated Analysis and Test result will be a Unit Diagonal Matrix as before

Various other variations on the basic idea are available, some include frequency shift as well as mode shape comparison.

Importance of Mode Identification

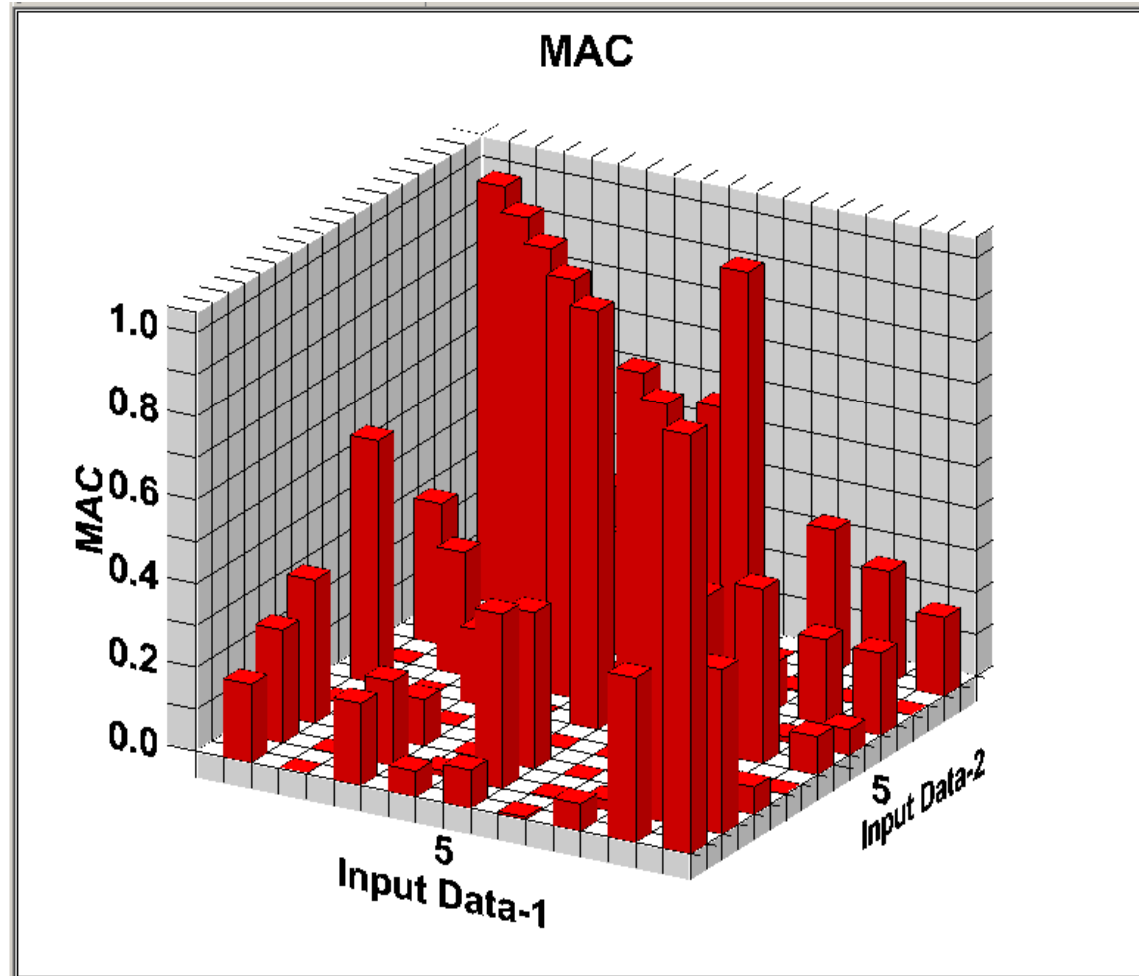

Importance of Mode Identification

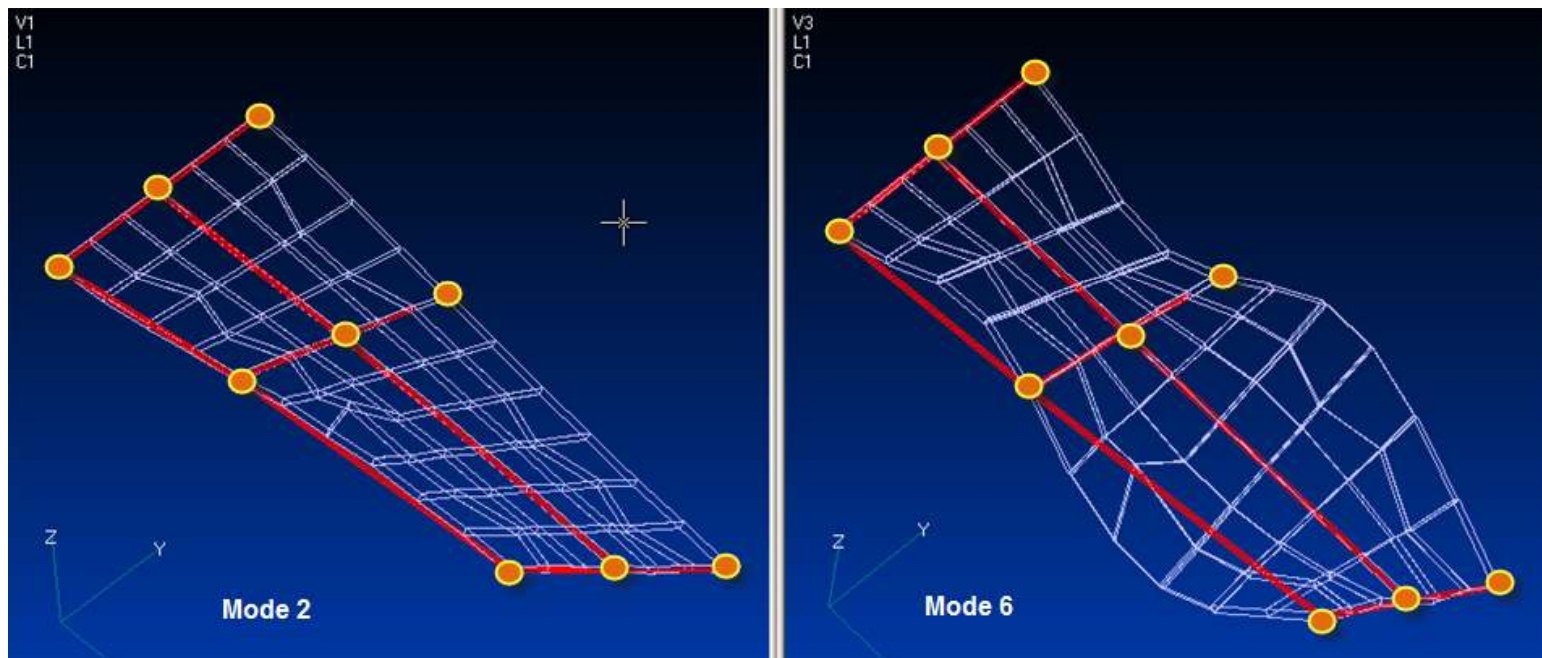

Importance of Mode Identification



Class Topics taking this further

- Project examples
- Describing and assessing modes
- Correlation Case studies

Introductory Dynamic FE Analysis Webinar

Agenda

What are Natural Frequencies, Normal Modes
- and why are they important?

Why can't I get displacements out of Normal Modes Analysis?
- are these 'real' values?

Importance of Mode Identification
- don't just quote a frequency!

What are Rigid Body Modes?
- my structure is elastic, why do I see them?

What are Rigid Body Modes?

– *my structure is elastic, why do I see them?*

For every DOF in which a structure is not totally constrained, it allows a Rigid Body Mode (stress-free mode) or a mechanism

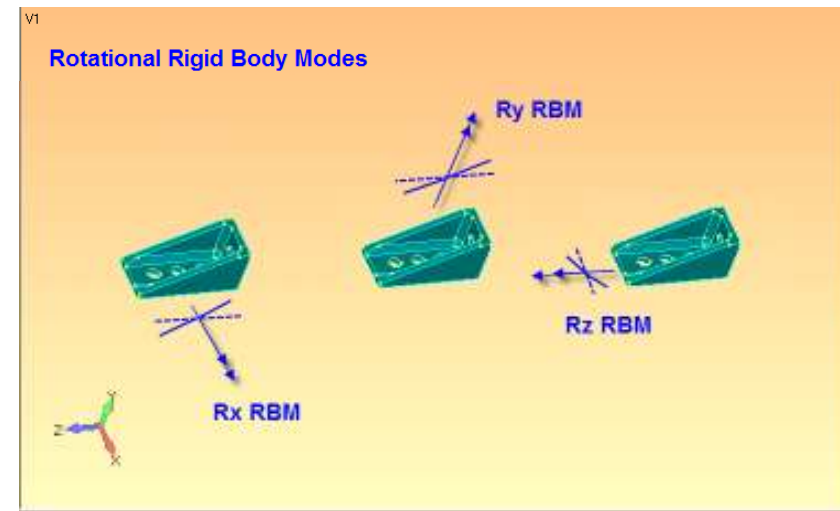
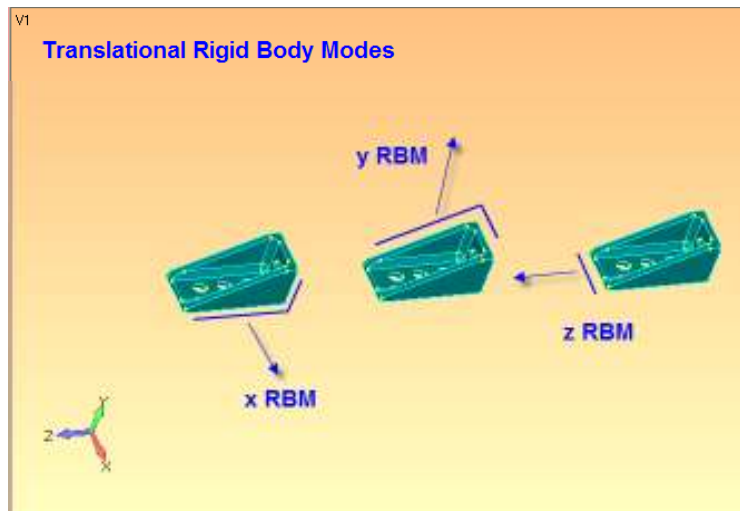

The natural frequency of each Rigid Body Mode should be close to zero

What are Rigid Body Modes?

- Classic mechanism due to element DOF mismatch

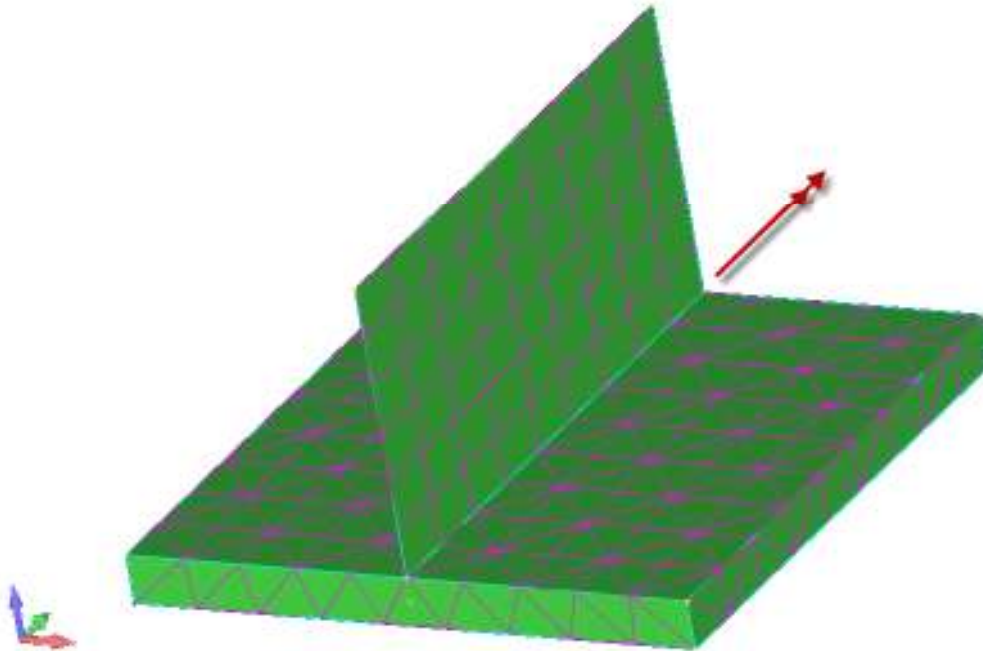

What are Rigid Body Modes?



Class Topics taking this further

- Typical causes of mechanisms
- Low order elastic eigenvectors
- Grounding and other checks



Introductory Dynamic FE Analysis Webinar

Agenda (continued)

Damping

What level of damping should I use?

Transient Analysis background

– that looks simple, stepping through time?

Frequency Response Analysis

– how is that different from transient analysis?

Quick peek at Shock Spectra and Random analysis

Damping

What level of damping should I use?

The only honest answer is - it depends!

Let's review what damping is and come back to the question ...

Damping

- If viscous damping is assumed, the equation of motion becomes:

$$m\ddot{u}(t) + b\dot{u}(t) + ku(t) = 0$$

- There are 3 types of solution to this, defined as:
 - ❖ Critically Damped
 - ❖ Overdamped
 - ❖ Underdamped
- A swing door with a dashpot closing mechanism is a good analogy:
 - ❖ If the door oscillates through the closed position it is **underdamped**
 - ❖ If it creeps slowly to the closed position it is **overdamped**
 - ❖ If it closes in the minimum possible time, with no overswing, it is **critically damped**

Damping

DAMPED FREE VIBRATION SDOF (Cont.)

- For the **critically damped** case, there is no oscillation, just a decay from the initial condition:

$$u(t) = (A + Bt)e^{-bt/2m}$$

- The damping in this case is defined as:

$$b = b_{cr} = 2\sqrt{km} = 2m\omega_n$$

- A system is **overdamped** when $b > b_{cr}$
- We are generally only interested in the final case - **underdamped**

Damping

DAMPED FREE VIBRATION SDOF (Cont.)

- For the underdamped case $b < b_{cr}$ and the solution is the form:

$$u(t) = e^{-bt/2m} (A \sin \omega_d t + B \cos \omega_d t)$$

- ❖ ω_d represents the Damped natural frequency of the system:

$$\omega_d = \omega_n \sqrt{1 - \zeta^2}$$

- ❖ ζ is called the Critical damping ratio and is defined by:

$$\zeta = \frac{b}{b_{cr}}$$

- ❖ In most analyses ζ is less than .1 (10%) so $\omega_d \approx \omega_n$

Damping

DAMPED FREE VIBRATION SDOF (Cont.)

- The graph is from a transient analysis of the previous spring mass system with damping applied

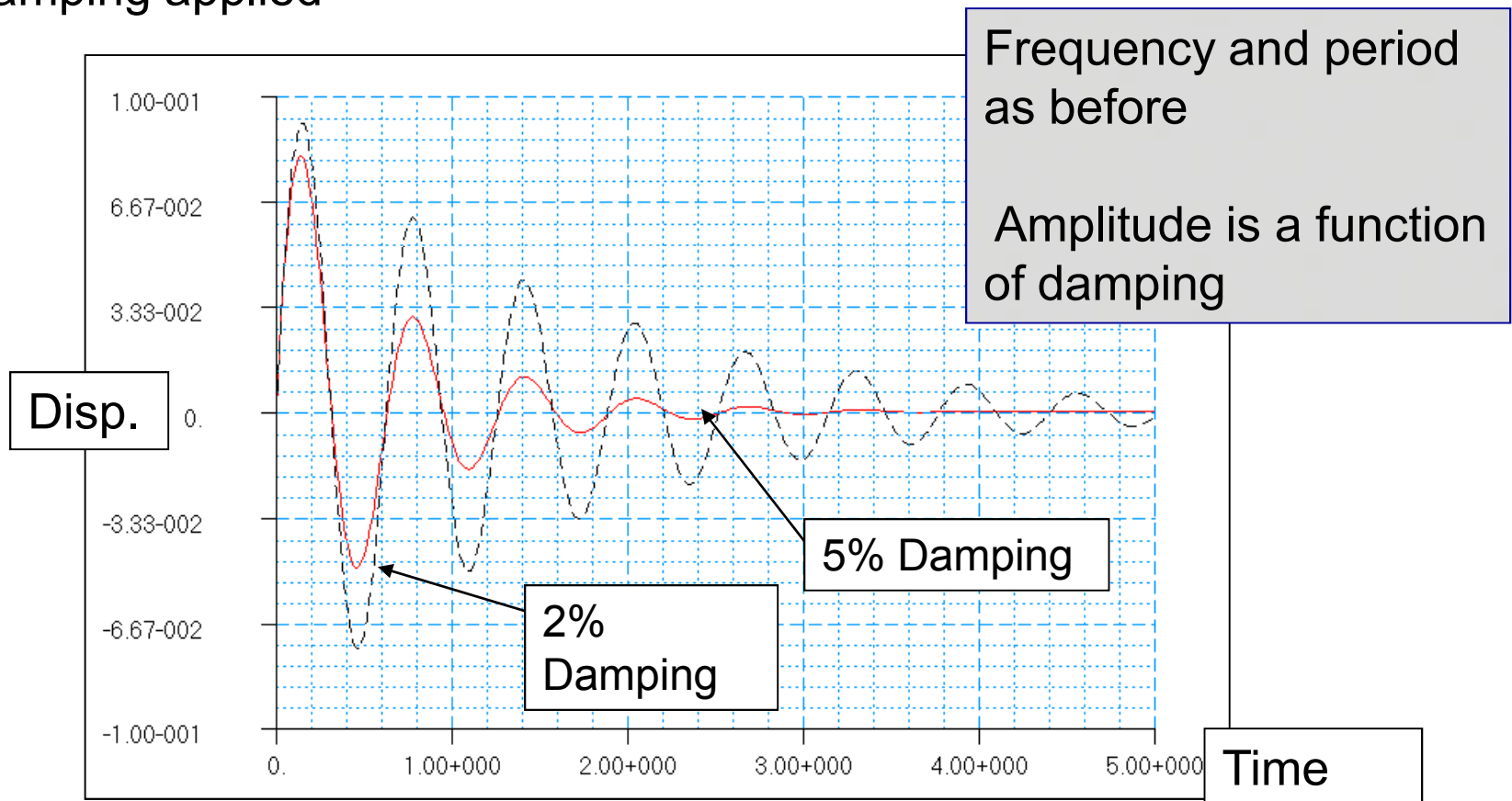

Damping

I have discussed viscous damping – but this is just one *simulation* method

Other types of damping simulations exist which may be preferable

- Modal damping – viscous damping, but linked to each mode shape
- Structural damping – overall or material based single slope frequency dependent damping
- Rayleigh damping – stiffness dominated region and mass dominated region
- Coulomb damping – based on ‘stick – unstick’ friction
- Nonlinear damping – in nonlinear solutions, can be dependent on many types of response including displacement, velocity, acceleration

Etc ...

The real world damping is a complex phenomena and is not fully understood
Testing and tuning against test results is the best approach

Damping

What level of damping should I use?

Now to answer the question, with a very rough rule of thumb and using critical damping ratio:

Vibration absorbing material could be 10% or greater – but*

Composite structure 3% - 10%

Rusty structure, friction clamps throughout 5% - 10%

Clean metallic structure bolted, riveted joints throughout 3% – 6%

Clean integrally machined structure 2% to 4%

Clean room integrally machined specially designed 1% to 2%

* Anything over 10 % is reaching the limits of linear analysis

Damping

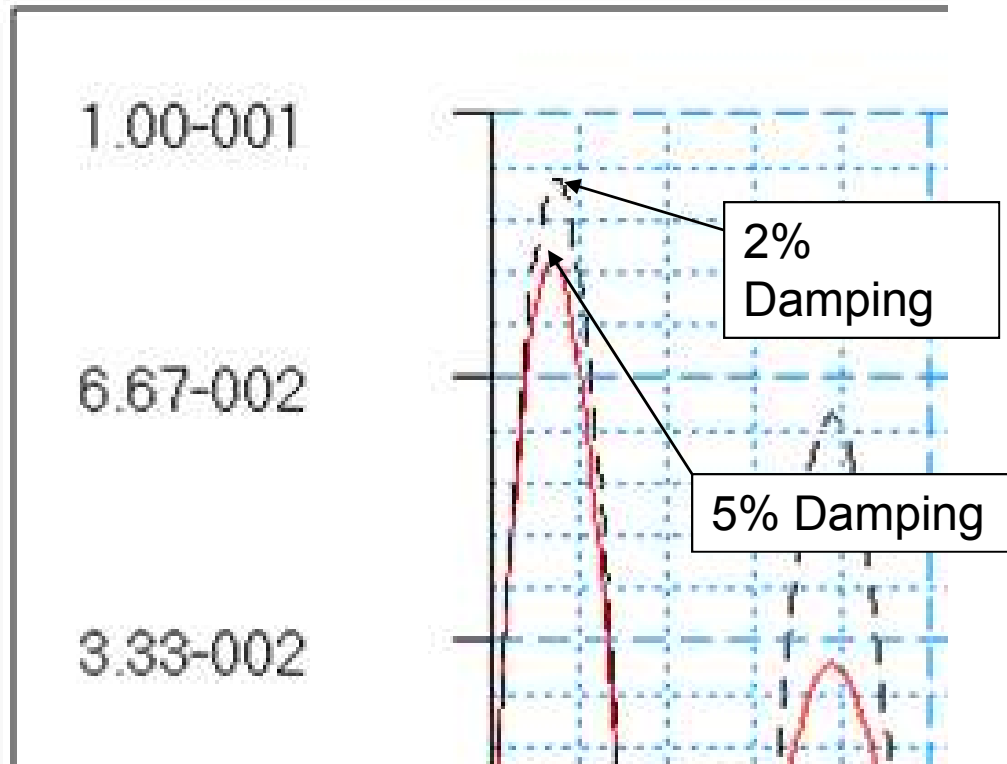

Bottom line is that a lower bound estimate is conservative, and upper bound is not

Always best to present a set of responses, based on two or three damping levels

Damping



Class Topics taking this further

- Damping theories in response analysis
- Damping case studies
- Checking damping levels
- Compound approach to damping

Introductory Dynamic FE Analysis Webinar

Agenda (continued)

Damping

What level of damping should I use?

Transient Analysis background

– that looks simple, stepping through time?

Frequency Response Analysis

– how is that different from transient analysis?

Quick peek at Shock Spectra and Random analysis

Transient Analysis Background

– *that looks simple, stepping through time?*

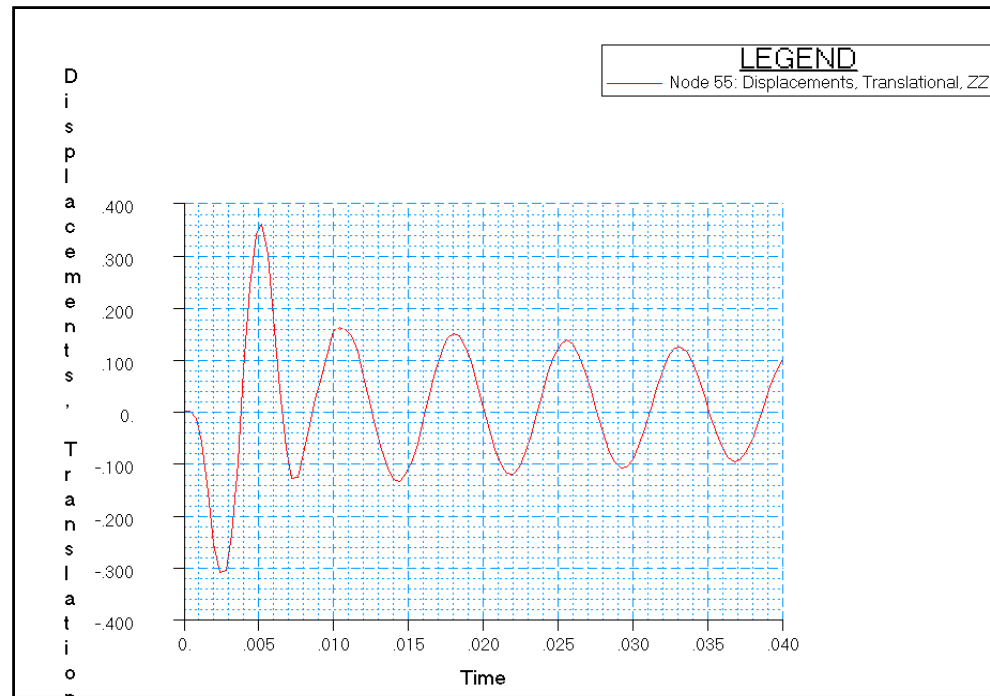

In general a transient analysis is most intuitive and we like to introduce response analysis using this approach

Transient Analysis Background

The Dynamic equation of motion is Δt

$$[M]\{\ddot{u}(t)\} + [B]\{\dot{u}(t)\} + [K]\{u(t)\} = \{P(t)\}$$

The response is solved at discrete times with a fixed time step

Using central finite difference representation for $\{\dot{u}(t)\}$ and $\{\ddot{u}(t)\}$ at discrete times

$$\{\dot{u}_n\} = \frac{1}{2\Delta t} \{u_{n+1} - u_{n-1}\}$$

$$\{\ddot{u}_n\} = \frac{1}{\Delta t^2} \{u_{n+1} - 2u_n + u_{n-1}\}$$

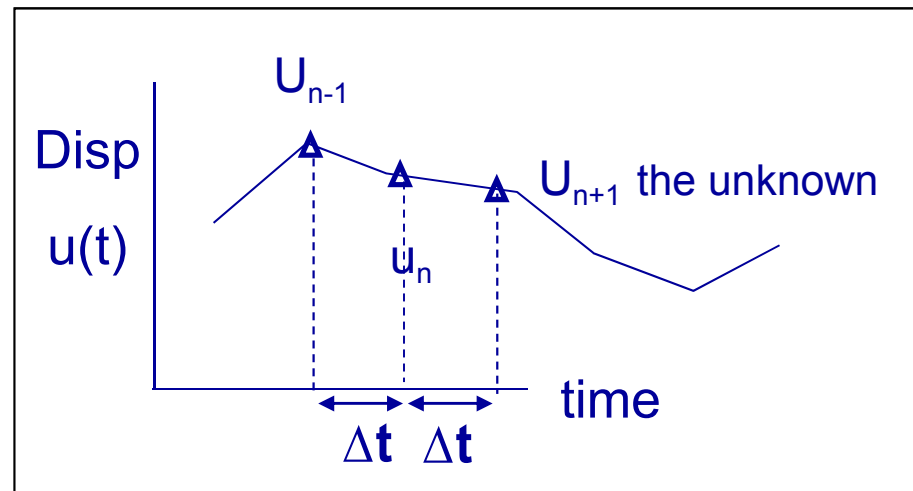

Transient Analysis Background

Some practical points to consider:

It is often easier to think in milliseconds (ms) - $.001s = 1ms$.

The time step chosen should be sufficiently small to capture the highest frequency of interest in the response. For example, if this value is 100 Hz, each time period is $.01s$ (10ms) so we need at the very least 5 steps to capture the response, i.e.. $\Delta t = .002s$ (2ms). The preferred minimum number is 10 steps per period.

The accuracy of the load input is similarly dependent on the time step chosen, so a loading with a 1000 Hz input will need at least Δt of $.0002s$ (.2ms) and preferably $.0001s$ (.1ms)

Shock loading will have very high frequency content, either as an applied load, or coming through a contact in non-linear

The smaller the value of Δt , the more accurate the integration will be, this may override the previous comments.

Transient Analysis Background

It may be cost effective in a large model to decrease Δt at a time of critical interest (say under impulsive loading) and increase it later. However, for linear transient analysis, changing Δt can be CPU expensive

Normally it will take a few runs to tune the model overall, and the effectiveness of this technique can be investigated

The number of times steps needs to be adequate to ensure all over swings are captured and that the response is decaying at the cut off point, with no surprises.

Reduce output to key nodes or elements to act as 'test' points. Only when model is thoroughly debugged then ask for full output

Transient Analysis Background

QA – *check frequency content matches what you expect* (the building block approach)

Use the graphical method shown, or a Fourier Analysis.

■ The time for 3 periods of oscillation is:
 $0.0330 - 0.0105 = 0.0225s$

■ Time period:
 $\frac{0.0225}{3} = .0075s$

■ Frequency:
 $\frac{1}{T} = 133.3 Hz.$

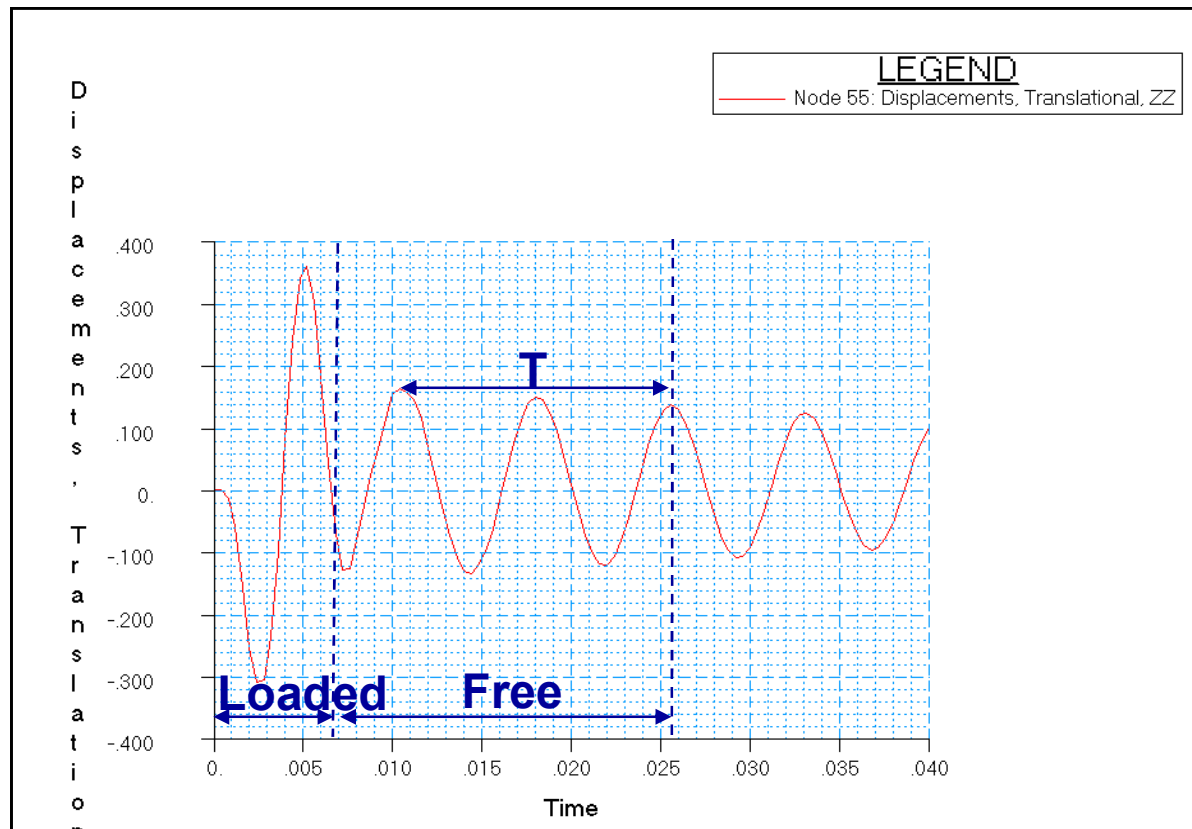

Transient Analysis Background

QA – *check damping values*

Use logarithmic decrement on successive peaks method to confirm total damping at that DOF

$$G = 2\zeta = \frac{d}{\pi}$$

Where:

$$d = \ln\left(\frac{d_1}{d_2}\right)$$

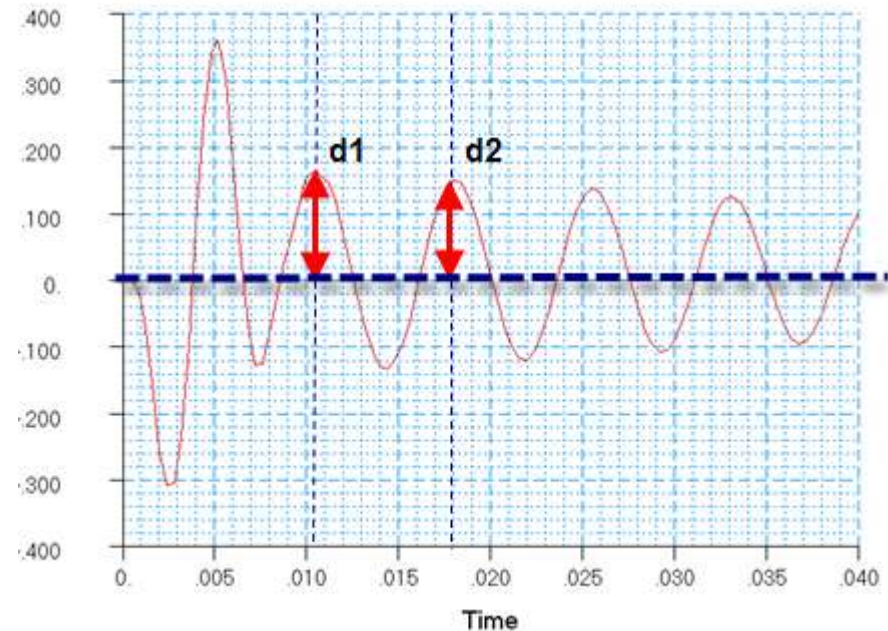

Transient Analysis Background

QA – *watch for aliasing*

Time steps are too coarse and misleading frequency content is seen

Peak responses are missed

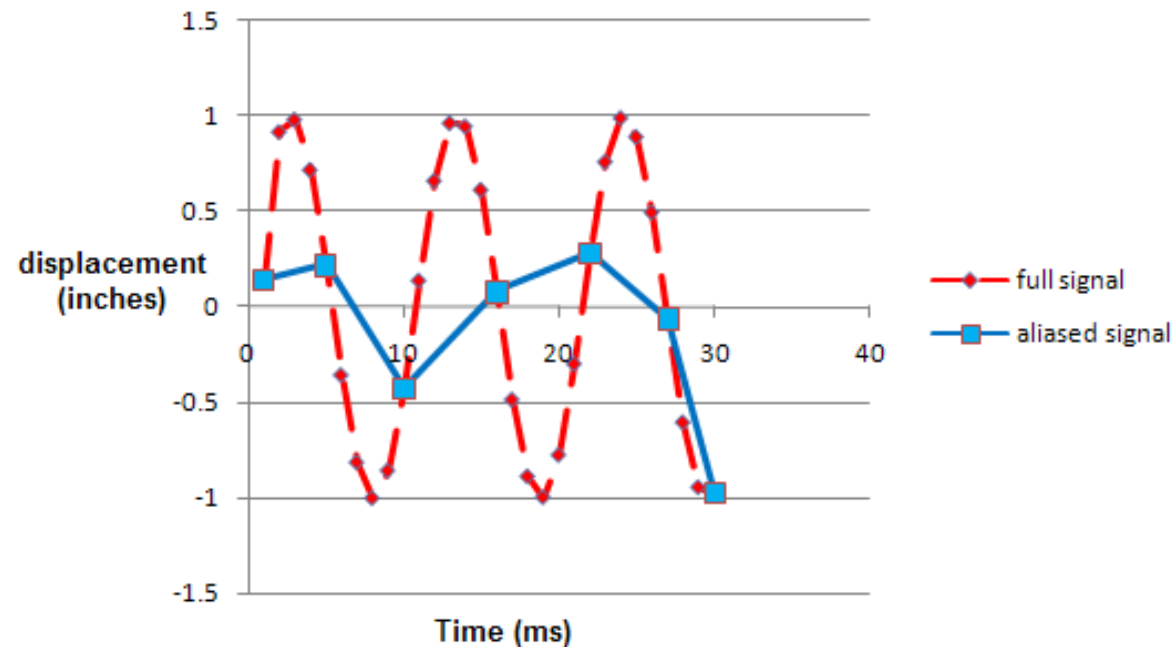

Transient Analysis Background

When and how to go nonlinear in impact:

Rule of thumb

- Bearing type contacts

Implicit



- Mother in Law hits parking spot post at 15 mph

Explicit



- Nigel Mansell hits Indy Car wall at 200 mph

Transient Analysis Background



Class Topics taking this further

- Direct and Modal methods
- Further damping assumptions
- Transient Case Studies
- Cook book approach for time step estimation
- Fourier Analysis of frequency content
- Large model strategies

Introductory Dynamic FE Analysis Webinar

Agenda (continued)

Damping

What level of damping should I use?

Transient Analysis background

– that looks simple, stepping through time?

Frequency Response Analysis

– how is that different from transient analysis?

Quick peek at Shock Spectra and Random analysis

Frequency Response Analysis

– *how is that different from transient analysis?*

- Transient response is intuitive and can be visualized as a time history of an event.

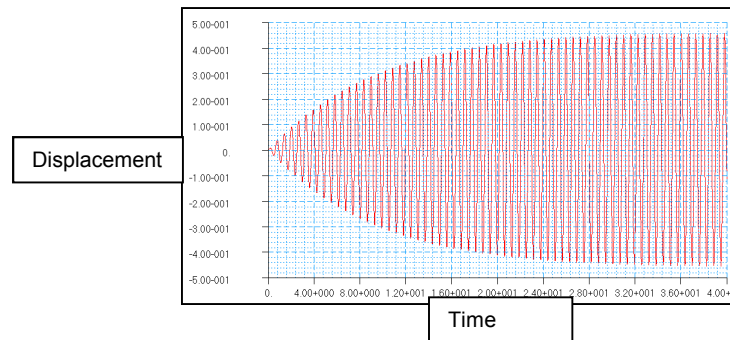

- Frequency response is best visualized as a response to a structure on a shaker table, Adjusting the frequency input to the table gives a range of responses

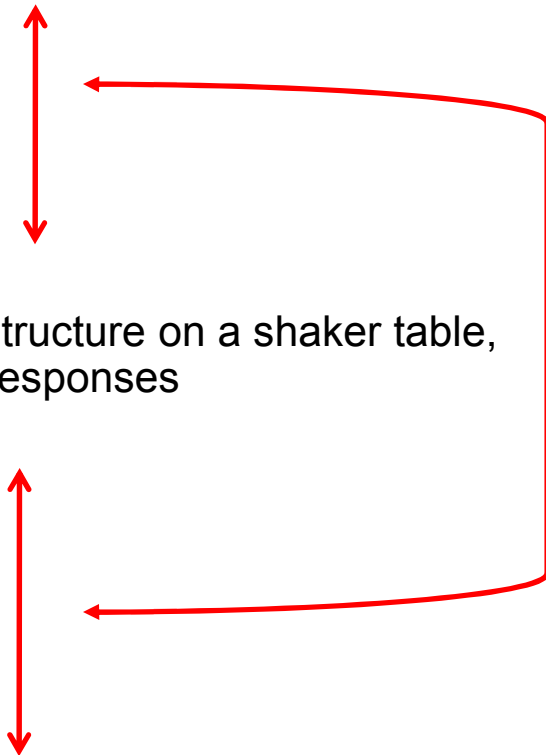
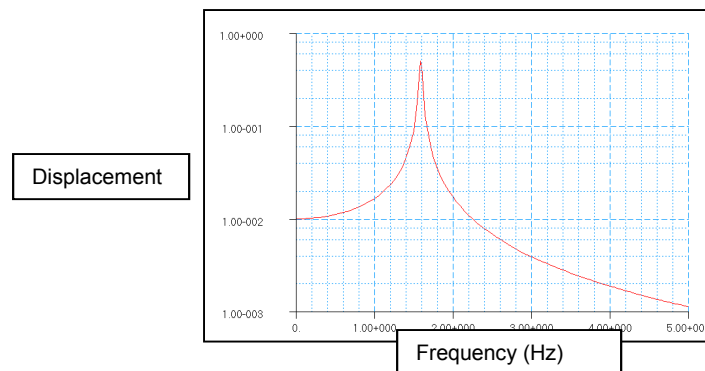

Frequency Response Analysis

- We now apply a harmonic **forcing function**: $p \sin \omega t$

- ❖ Note that ω is the DRIVING or INPUT frequency

- The equation of motion becomes:

$$m\ddot{u}(t) + b\dot{u}(t) + ku(t) = p \sin \omega t$$

- The solution consists of two terms

- ❖ The initial response, due to initial conditions which decays rapidly in the presence of damping
 - ❖ The steady-state response as shown:

$$u(\omega) = p/k \frac{\sin(\omega t + \theta)}{\sqrt{(1 - \omega^2/\omega_n^2)^2 + (2\zeta\omega/\omega_n)^2}}$$

- ❖ This equation is described on the next page

Frequency Response Analysis

- This equation deserves inspection as it shows several important dynamic characteristics:

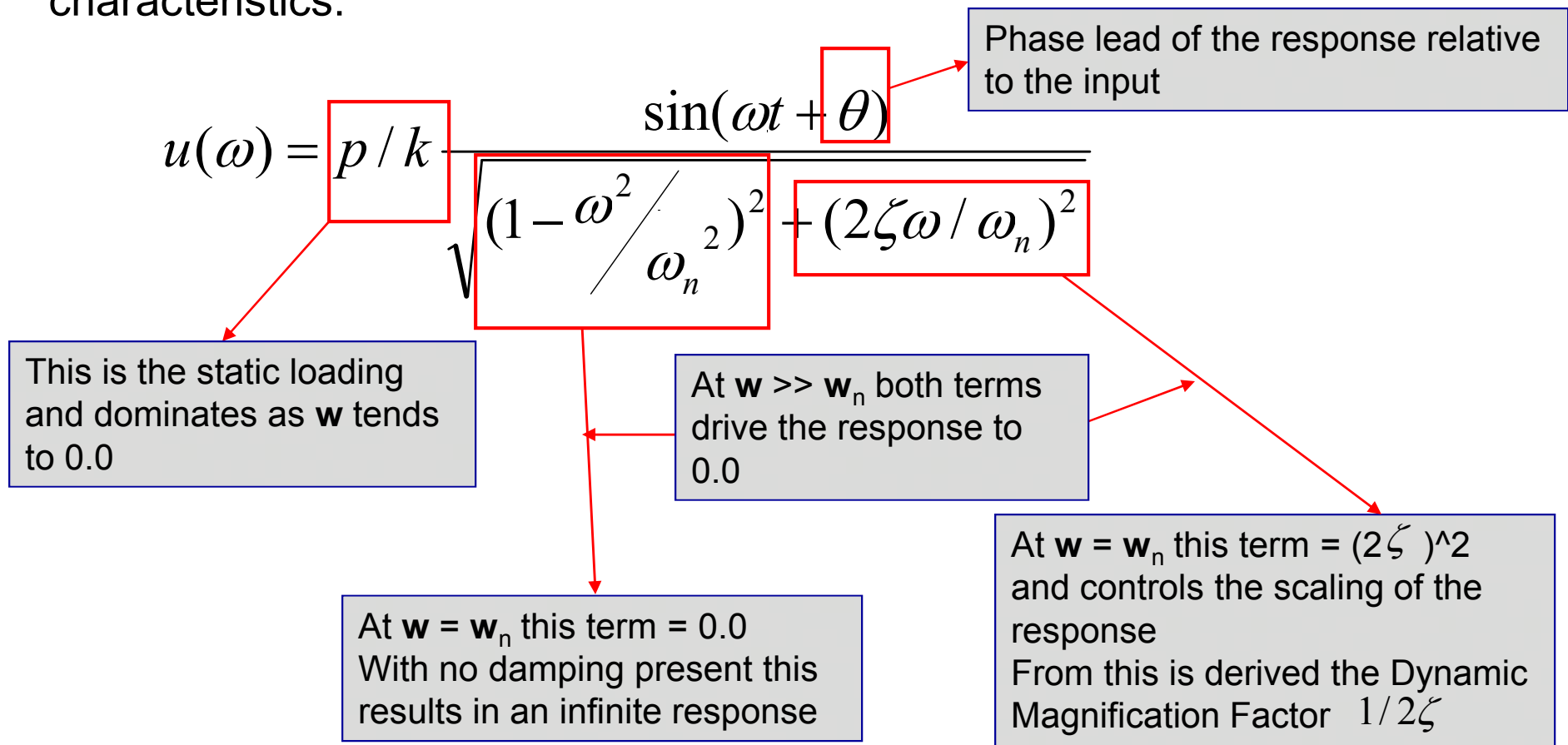

Frequency Response Analysis

□ Summary:

❖ For $\frac{\omega}{\omega_n} \ll 1$

- Magnification factor $\longrightarrow 1$ (static solution)
- Phase angle $\longrightarrow 0^\circ$ (response is in phase with the force)

❖ For $\frac{\omega}{\omega_n} \gg 1$

- Magnification factor $\longrightarrow 0$ (no response)
- Phase angle $\longrightarrow 180^\circ$ (response is out of phase with the force)

❖ For $\frac{\omega}{\omega_n} \approx 1$

- Magnification factor $\longrightarrow 1/2\zeta$ (dynamic magnification factor)
- Phase angle $\longrightarrow 90^\circ$ (response is in transition)

Frequency Response Analysis

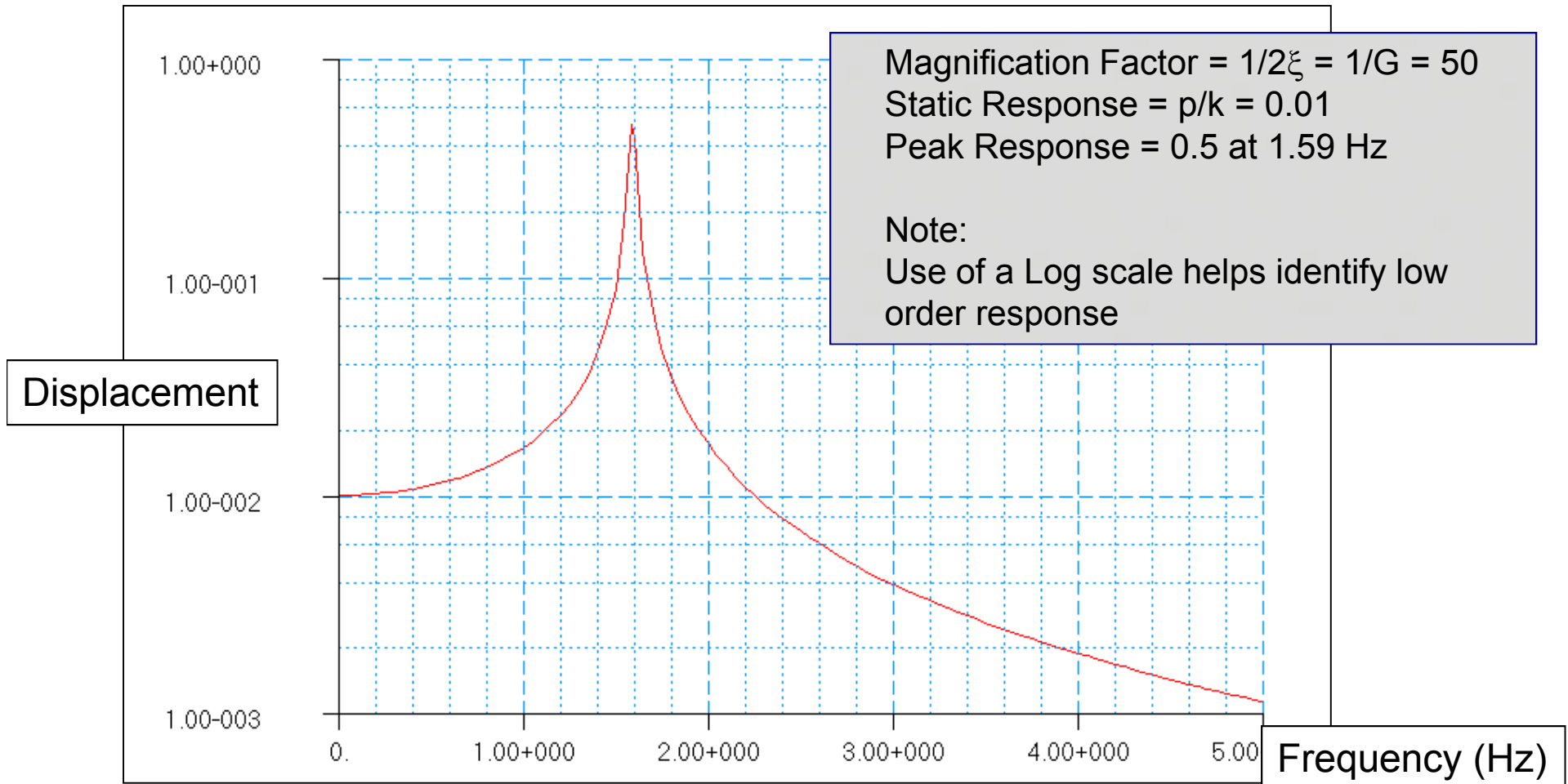

Frequency Response Analysis

Some practical points to consider:

Frequency Response calculation points (sometimes called spectral lines):

Must be at each natural frequency to ensure that the peak responses are captured

Must be spread around each natural frequency to capture a good 'shape'

A general spread of points is required to capture the overall trend of the curve

The number of calculation points will increase CPU cost and output quantities

As with transient – debug the model using key nodes and element responses before running full output requests

Use log scales to help visualization

Avoid responses or definitions at 0.0 hz - $\log_{10} 0.0 = 1.0$!

Frequency Response Analysis



Class Topics taking this further

- Modal and Direct methods
- Further damping methods
- Large model strategies
- Case studies

Introductory Dynamic FE Analysis Webinar

Agenda (continued)

Damping

What level of damping should I use?

Transient Analysis background

– that looks simple, stepping through time?

Frequency Response Analysis

– how is that different from transient analysis?

Quick peek at Shock Spectra and Random analysis

Introductory Dynamic FE Analysis Webinar

Agenda (continued)

Damping

What level of damping should I use?

Transient Analysis background

– that looks simple, stepping through time?

Frequency Response Analysis

– how is that different from transient analysis?

Quick peek at Shock Spectra and Random analysis

Introductory Dynamic FE Analysis Webinar

Agenda (continued)

Damping

What level of damping should I use?

Transient Analysis background

– that looks simple, stepping through time?

Frequency Response Analysis

– how is that different from transient analysis?

Quick peek at Shock Spectra and Random analysis

Quick peek at Shock Spectra and Random analysis

Random vibration is vibration that can be described only in a statistical sense. Its instantaneous magnitude at any time is not known; rather, the probability of its magnitude exceeding a certain value is given.

Examples include earthquake ground motion, ocean wave heights and frequencies, wind pressure fluctuations on aircraft and tall buildings, and acoustic excitation due to rocket and jet engine noise.

Random environment is characterized by a Power Spectral Density (PSD)

FE solvers perform random response analysis as post processing to unit frequency response.

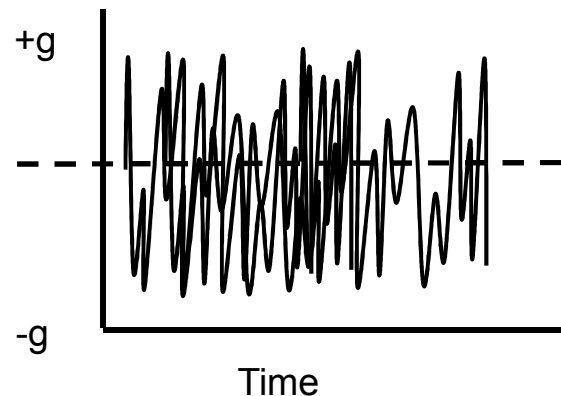

Quick peek at Shock Spectra and Random analysis

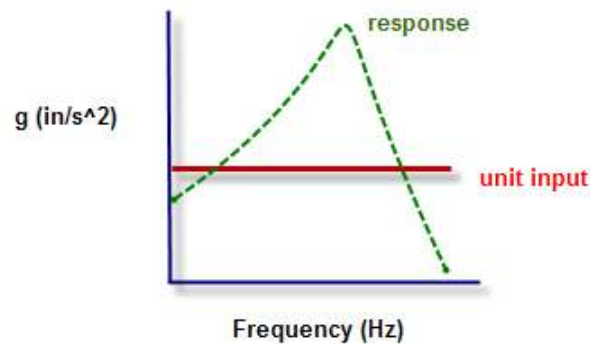

Response at a DOF due to unit input (TF)

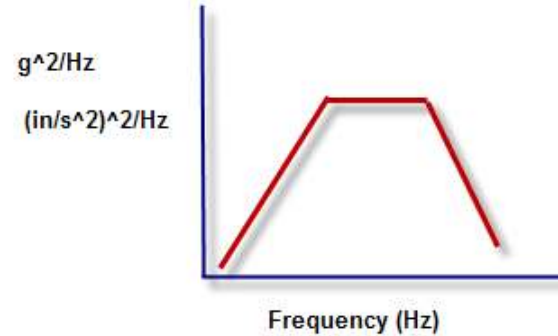

PSD Input Definition

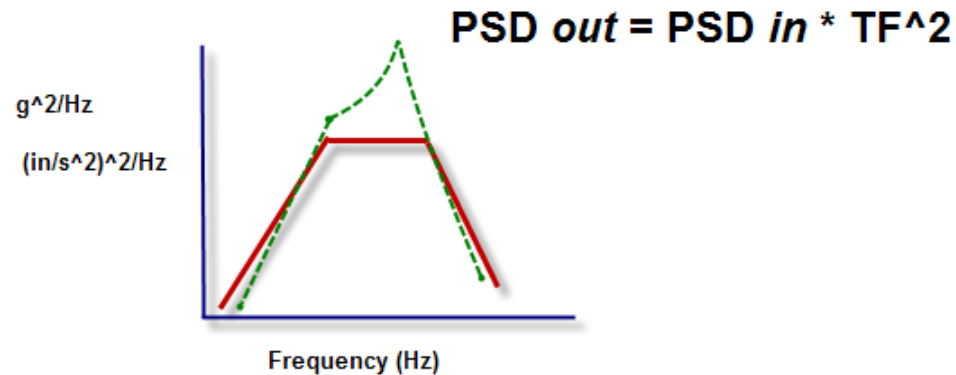

PSD response at DOF

Quick peek at Shock Spectra and Random analysis

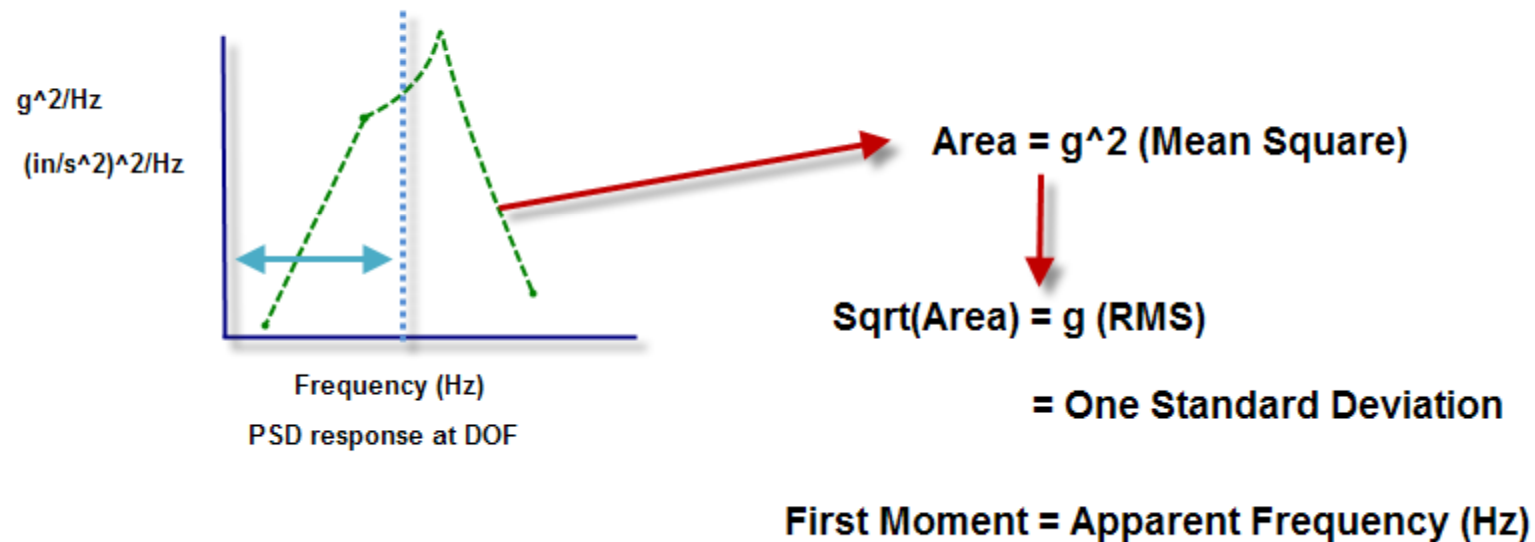

Quick peek at Shock Spectra and Random analysis

Shock Spectra

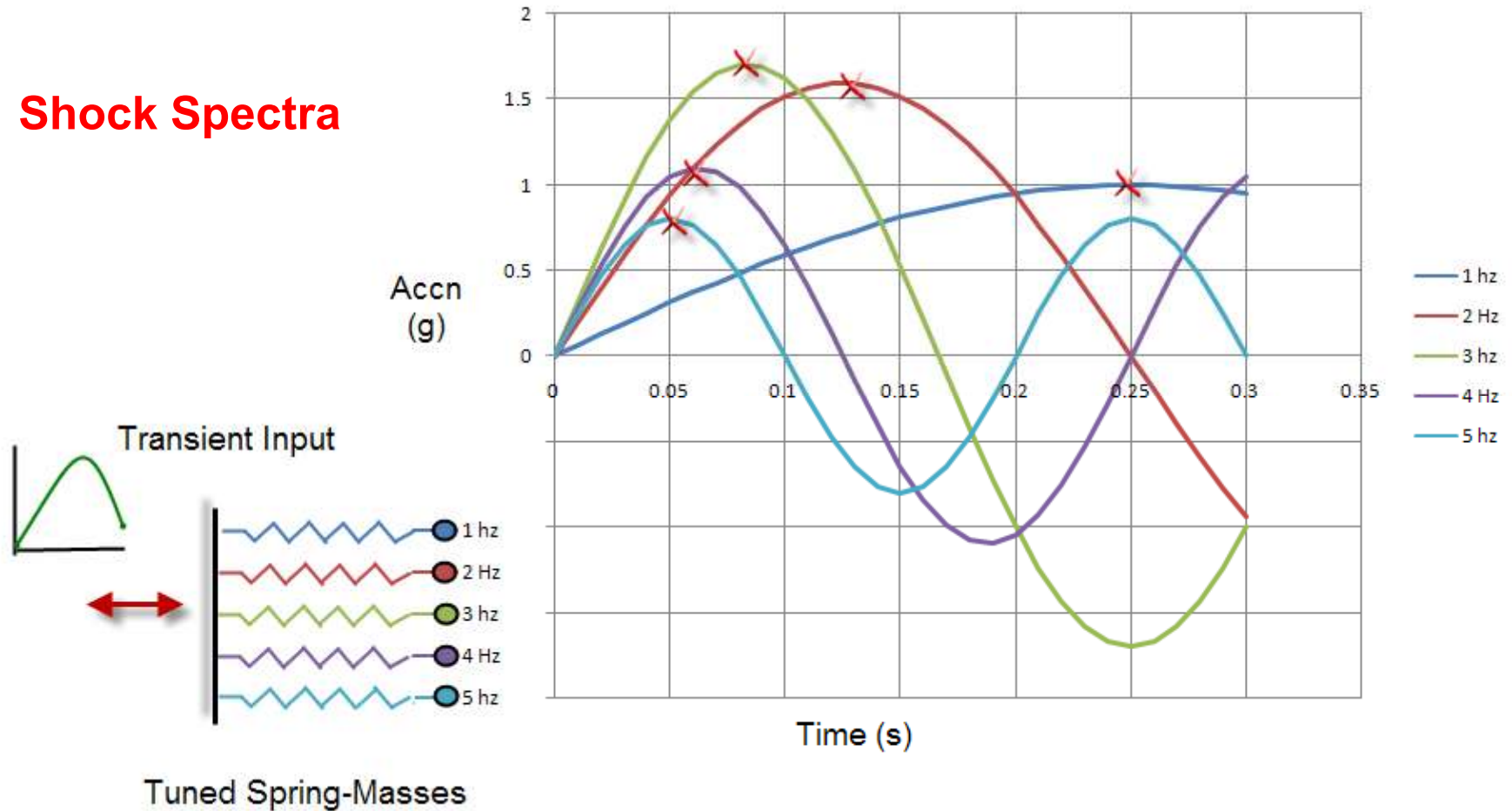

Quick peek at Shock Spectra and Random analysis

A substructure or piece of equipment with frequency 3.5 Hz would expect to see a peak base acceleration of 1.4 g

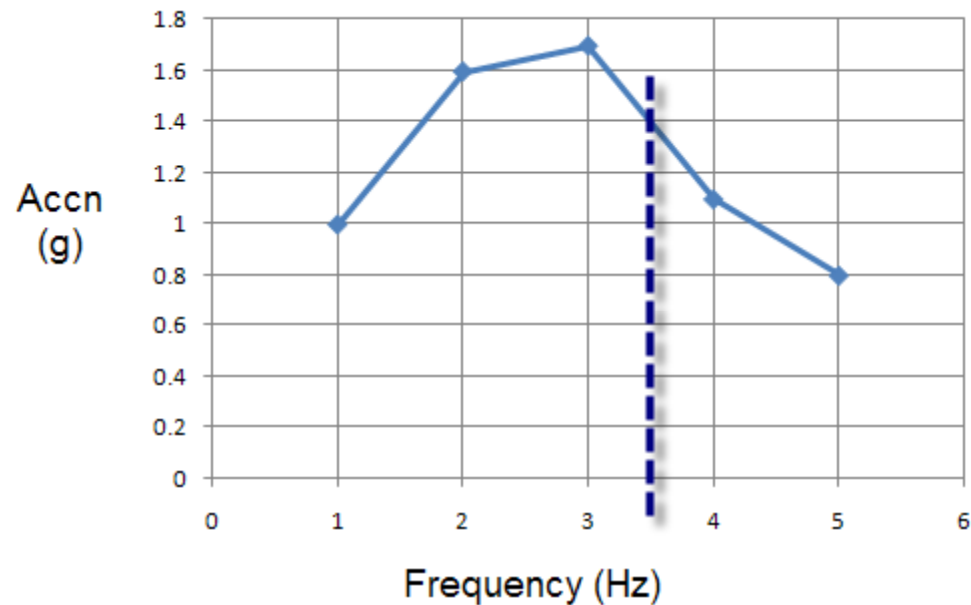
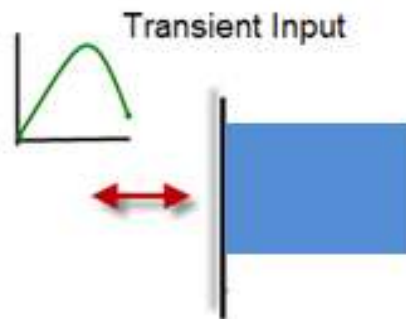

Shock Response spectra

No coupling is assumed between primary and substructure

Quick peek at Shock Spectra and Random analysis



Class Topics taking this further

- Description of Random background
- PSD theory and practical evaluation
- Case study with full random output
- Introduction to Vibration fatigue
- Shock spectra case studies and further theory

Conclusions

CHECK LIST FOR NORMAL MODES PRIOR TO DOING FURTHER ANALYSIS

RBM's - are they as expected

Is the frequency range adequate (we will discuss this more in the section on modal effective mass)

Are the modes clearly identified

Is mesh density adequate

Is the element type appropriate

Is the mass distribution correct

Is coupled vs. lumped mass important

Are the internal joints modeled correctly

Are the constraints modeled correctly

Do the results compare with hand calcs, previous experience or test

Conclusions

CHECK LIST FOR RESPONSE ANALYSIS

Make sure the modes are reasonable

Transient - Plan time steps and duration

Frequency response – Plan frequency range and spread

Identify forms of damping and what methods to simulate

Plan a exploratory key point approach to the results, don't output all data

Transient results – check damping, frequency content, aliasing, duration

Frequency response results - check resonant frequencies captured and good spread of points, check magnification factor against damping and low frequency results approaching static

All forms of response – check driven nodal response against input

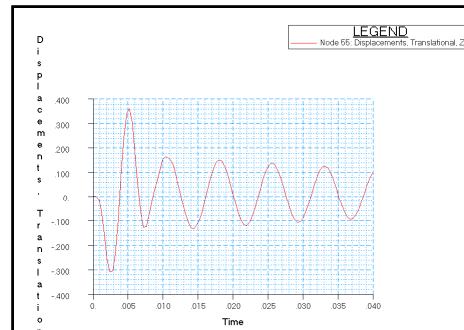
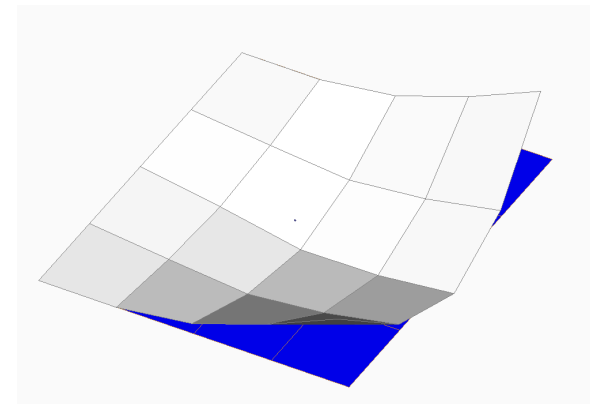
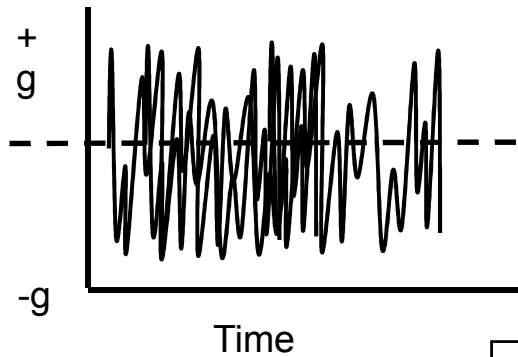

Q and A

www.nafems.org

www.fetraining.com

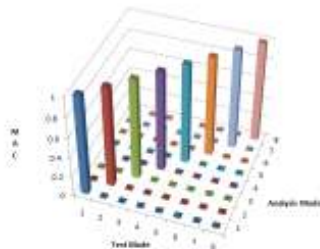



THE INTERNATIONAL ASSOCIATION
FOR THE ENGINEERING ANALYSIS COMMUNITY

Thank you!

matthew.ladzinski@nafems.org