

DEP
MeshWorks

The power of CAE to

ACCELERATE. TRANSFORM. AUTOMATE. INNOVATE.



DEP
MeshWorks

NEW! Innovative ROM Module



Highly automated Process workflows



Intelligent AI/ML CAE framework



Advanced Post processing



Rapid Meshing & Modeling

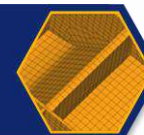

NEW! Productive Electrification Module



Groundbreaking Concept Modeling



Next generation CAD/CAE Morphing



Cutting-edge CAE parametrization



Time Saving MDO

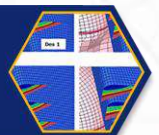

All New DEP MeshWorks

DEP MeshWorks, from Detroit Engineered Products (DEP) is a game-changing CAE platform that's set to disrupt the world of product development.

The new power-packed version of MeshWorks features advanced toolsets for engineering applications like EV and ADAS development, alongside backend AI/ML algorithms for rapid go-to-market strategies. This makes it a comprehensive and robust CAE powerhouse.

With modules for ultra-fast concept CAE and CAD model generation, advanced meshing and morphing, streamlined process automation, and refined concept modeling, engineers can now achieve outstanding results more quickly than ever before. The latest, feature-rich version of MeshWorks stands as the ultimate, state-of-the-art suite of CAE solutions for product design and engineering.

This new version empowers users with the capabilities of CAE at their fingertips:

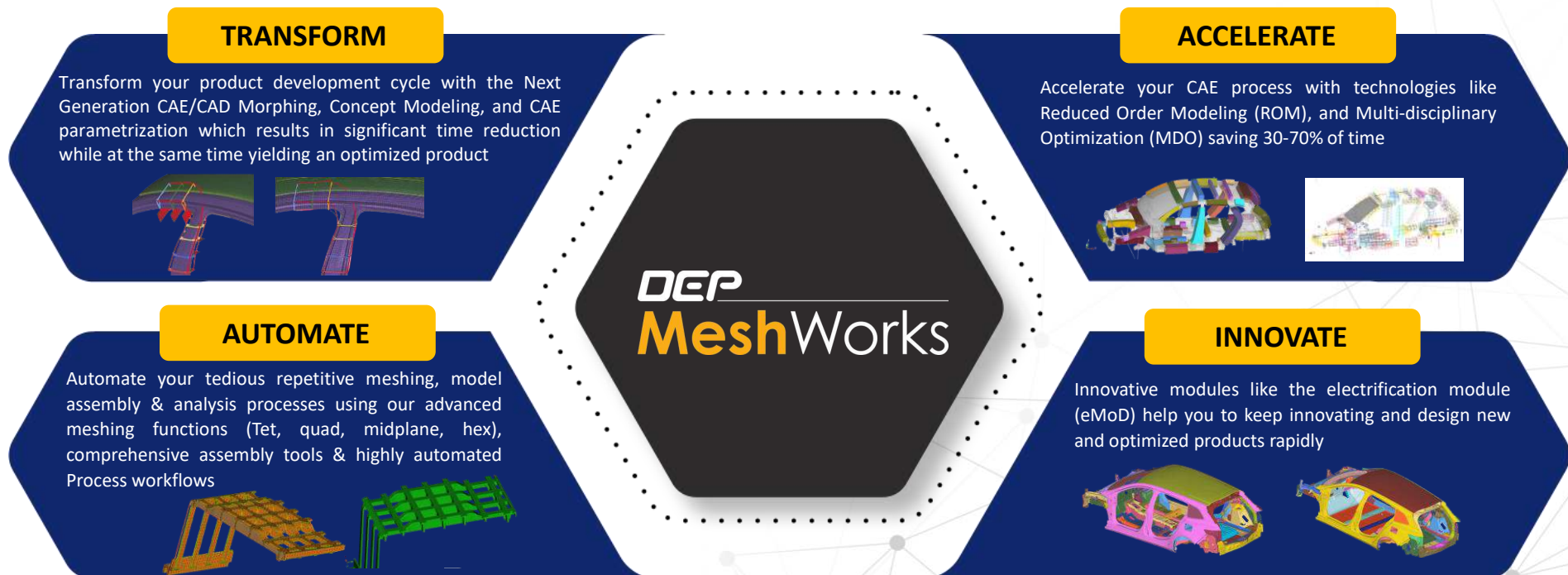

NEW! Innovative ROM Module



NEW! Productive Electrification Module



Highly automated Process workflows



Groundbreaking Concept Modeling



Intelligent AI/ML CAE framework



Next generation CAD/CAE Morphing



Advanced Post processing



Cutting-edge CAE parametrization



Rapid Meshing & Modeling



Time Saving MDO



Value Proposition for MeshWorks Users

- Using MeshWorks ROM, users can save up to 50% of analysis solver time enabling quick CAE turn-around-time (TAT).
- The learning curve is minimal thanks to the highly automated ROM functions.
- Since the ROM is parametric, subsequent optimization can be carried out very fast due to significant solver time reduction.
- Standard manufacturable sections can be created using the optimized ROM.
- Using the ConceptWorks module optimized sections from ROM can be converted using 1D to 3D functions.

Reduced Order Modeling

Customization & Optimization at lightning speed

- Highly automated Reduced Order Modeling (ROM) module in MW take the tediousness away in ROM creation.
- It converts a complex & detailed FE model to a simplified, high-fidelity model. With automated structure topology intelligence, creation of 3D to 1D model, beams, springs etc. are done effortlessly.
- ROM models created also are automatically made parametric nicely tying geometric cross-sections to beam properties.
- MeshWorks enabled ROM process allows correlation between detailed and reduced order representations.
- Section synthesis tools are part of the ROM module that will optimize any given section to meet target load criteria.
- ROM modeling criteria differs vastly between different disciplines such as Crash vs. NVH. MeshWorks ROM module has specific tools for each discipline.

BIW Architecture Development – ROM approach

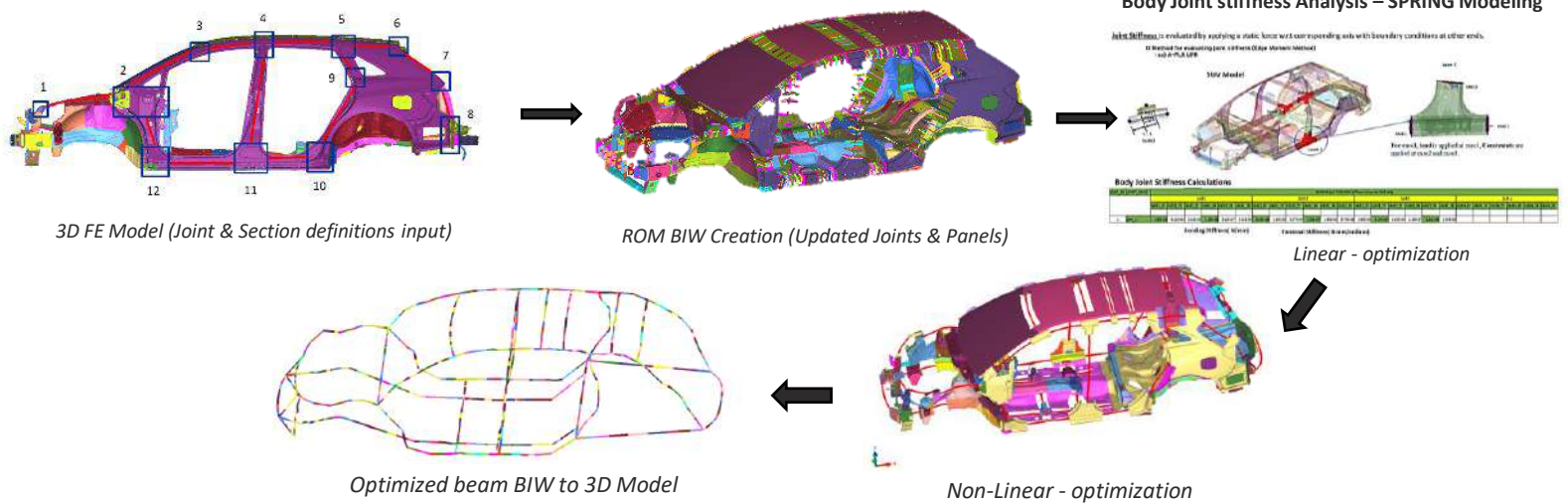

Uniqueness of MeshWorks

1. Back-and-forth conversion of Detailed model to beams & springs and then back to detailed model after analysis in a rapid time frame – 3D to 1D.
2. Automatic topological identification of tubular & joint regions and appropriate ROM modeling for those regions.
3. Auto-Parametrization (linear & non-linear) of ROM models enabling FAST Optimization.
4. Auto conversion of optimized ROM to 3D models through ConceptWorks – 1D to 3D.

- Cross sections as input:
 - Master sections from library
 - Reference baseline sections
 - Topology load path with positioned standard sections
- Extrude sections (3D FE Models) and generate baseline analysis
- Parametrization of sections – shape, size and material parameters
- DOE and optimization
- Optimized section generation
- 3D FE models

Section Optimization: Linear and Non-linear

Input Sections: can be either criterion section from library or base FE reference sections

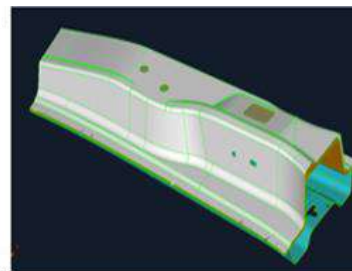
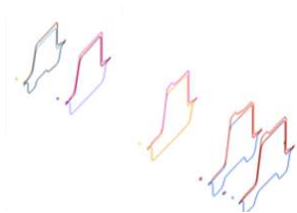
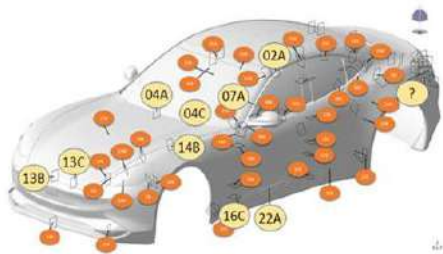

3D FE and CAD models

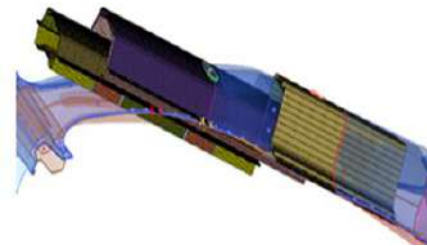

- 1D sections extruded to create 3D FE model. FE model can be used for linear and non linear Loadcases.
- Generate data decks for all the Loadcases – based on interest these Loadcases can be added or subtracted.

- | | |
|-------------------------|-------------------------|
| 01_Bending_4Pts_MXplus | 07_Bending_3Pts_MYplus |
| 02_Bending_4Pts_MXminus | 08_Bending_3Pts_MYminus |
| 03_Bending_4Pts_MYplus | 09_Torsion_MZplus |
| 04_Bending_4Pts_MYminus | 10_Torsion_MZminus |
| 05_Bending_3Pts_MXplus | 11_Traction_FZplus |
| 06_Bending_3Pts_MXminus | 12_Compression_FZminus |

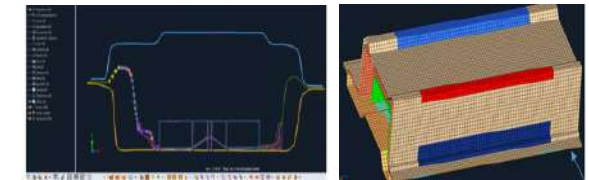

- Section parametrization for shape
- Material parameters
- Thickness parameters

- DOE
- Designs Generation
- Post-processing and results tabulation
- Optimization

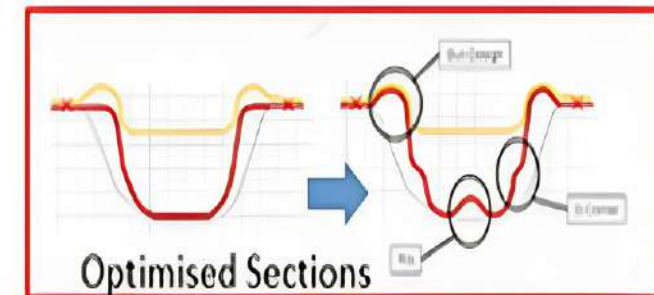

NEW! Innovative ROM Module



NEW! Productive Electrification Module



Highly automated Process workflows



Groundbreaking Concept Modeling



Intelligent AI/ML CAE framework



Next generation CAD/CAE Morphing



Advanced Post processing



Cutting-edge CAE parametrization



Rapid Meshing & Modeling



Time Saving MDO

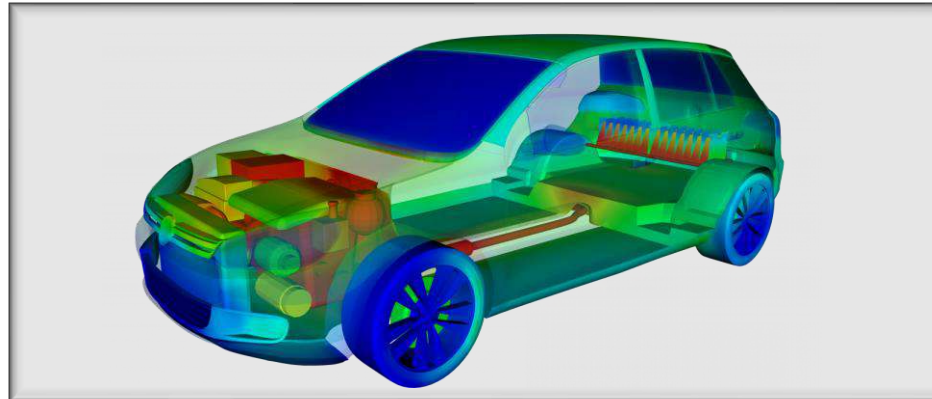

Value Proposition for MeshWorks Users

1. Parametric CAE technology applied to Electrification, and 'Ready-to-use' CAE Workflows designed for EV Analysis are unique to MeshWorks.
2. Due to the Parametric EV CAE Models generated by eMOD, significant range improvement can be achieved by the Electric Vehicle being optimized for weight and aero-drag parameters.
3. With eMOD, user can be assured of performance improvement (e-Motor performance, high frequency noise mitigation etc.) through parametric optimization.
4. eMOD generated parametric CAE models (for example a full battery pack assembly) with auto stack-up adjustment supports robust optimization accounting for dimensional variation
5. The 'Ready-to-use' Electrification CAE Workflows greatly reduces learning curve for new users.
6. The coupler technology connecting several solvers meant for Electrification analysis is unique in MW.
7. EV development cycle time can be reduced by more than 30% thanks to virtual CAE engineering driven by eMOD.

Electrification Module - eMOD

Digital Twin for Electric Vehicle

1. eMOD, is a collection of specialized tools for modeling all components of an electric vehicle, and is used in electrification processes starting from system analysis to component analysis for EVs.
2. It comprises of 3 layers and each layer has unique capabilities to support electric vehicle development.
3. The first layer is which is the foundation layer consists of specialized 'Meshing & Model Assembly tools' which supports Meshing for E-Propulsion units & vehicle sub-systems - both structures & CFD (Battery Drive Unit, Inverters, E-Vehicle Structures).
4. The second mid-layer houses the 'Collection of Couplers' which is the group of interfacing tools & utilities the provides the connectivity between different solvers that are used for electrification analysis.
5. The last & final layer that completes this eMOD package is the workflow layer that guides the user with CAE workflows for Electrification CAE analysis.
6. With the use of above features in eMOD, one can not just create the Electrification CAE models rapidly but can parameterize them for Structural & CFD Analysis leading to faster optimization cycles.

PA Automation

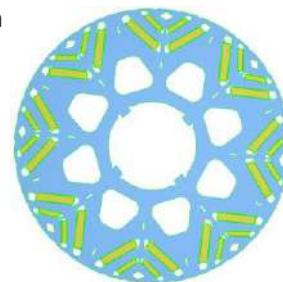

Input CAD

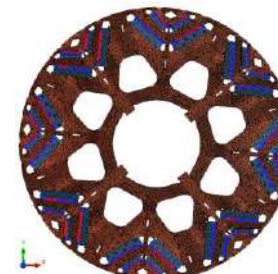

2D Planer Mesh Full Rotation

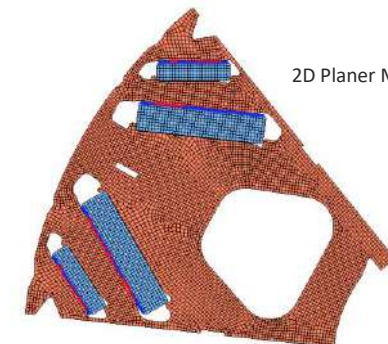

2D Planer Mesh - Single Pole

Uniqueness of MeshWorks

1. The eMOD feature comes with unique meshing options for EV components. For instance, the battery modeling functions are tailored for cell level, module level & pack level meshing & this in-built variety of meshing options makes the tool comprehensive for Crash, NVH & Durability disciplines.
2. The toolset encompasses Special Assembly & Connection tools that aims to create assembly connections between EV components (Bolt Connections, contact between cells, etc.) in a fast & efficient manner.
3. The models as & when created in MW eMOD, becomes parametric, thereby facilitating modifications & optimization at a faster pace.
4. With MW eMOD, Variational studies & Robust optimization is done at lightening speed.
5. Customized ConceptWorks functions can convert a conventional ICE vehicle CAE model to EV model within 1 week !!
6. The eMOD coupler utility, automatically converts the output model from one solver to input model for other solver which is predominantly used for Electrification Models (Eg: Electromagnetism from Maxwell to Vibration in Nastran).
7. eMOD function holds a major differentiation in terms of its 'In-Built' electrification workflows that are 'ready-to-use'.

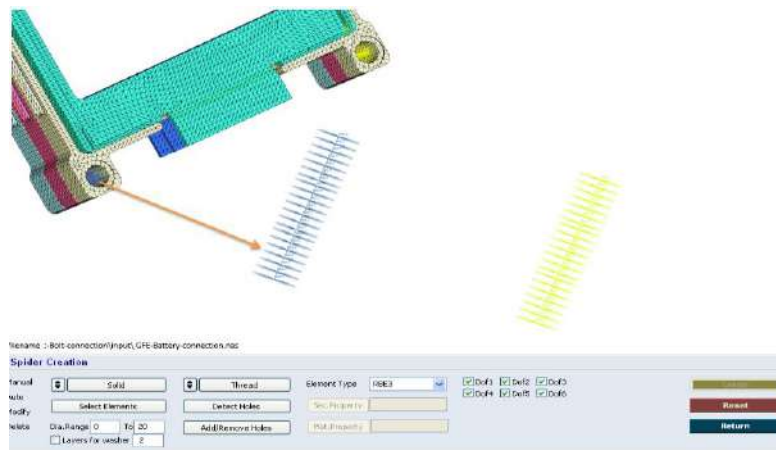

Bolt Connection

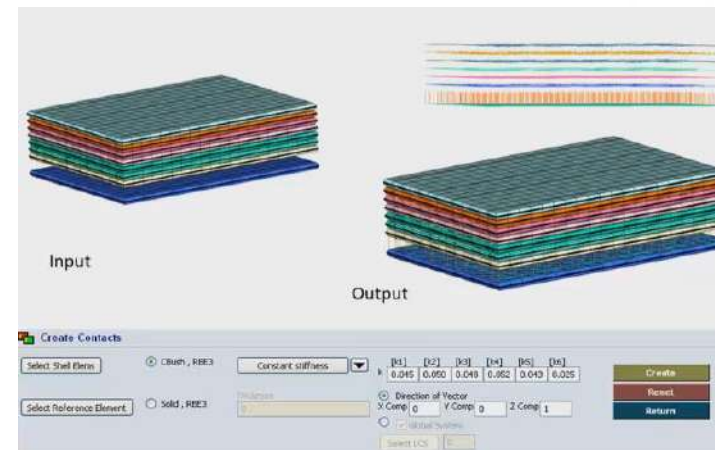

EMA ANALYSIS LEADING TO CHT & STRUCTURAL ANALYSIS

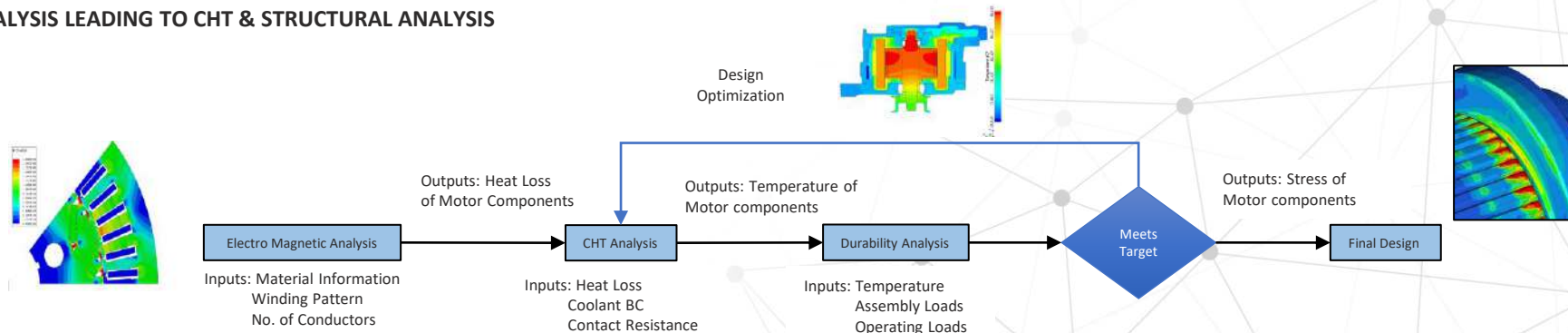

NEW! Innovative ROM Module

NEW! Productive Electrification Module

Highly automated Process workflows

Groundbreaking Concept Modeling

Intelligent AI/ML CAE framework

Next generation CAD/CAE Morphing

Advanced Post processing

Cutting-edge CAE parametrization

Rapid Meshing & Modeling

Time Saving MDO

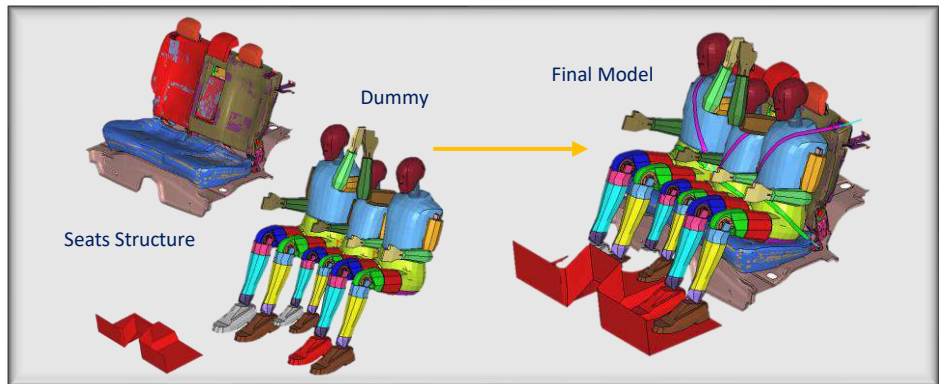

Value Proposition for MeshWorks Users

1. The specialized PA's that are available in MW23 help users save a lot of time.
2. The PA function in MW is a visual & easy method to create PA where no scripting knowledge is required which in-turn reduces the time used in the PA creation process.
3. Many of the 'specific' needs of users are taken care of using the pre-packages PAs.
4. With this institutionalized PA process, customers can keep the required proprietary functions in-house, with no need for sharing.
5. Processes can be standardized across the entire organization.
6. Manipulations possible at CAD/CAE geometry level.

Process Automation

Highly automated process workflows

1. Repetitive CAE processes can be rapidly automated using a fast Record > Create-GUI >Plumb > Publish process using MW Process Automation function.
2. Very complicated geometry and mesh creation processes can be automated with virtually no scripting or programming expertise.
3. The process automation can be performed in as simple of way as just a 'drag & drop' action to create GUI and plumb it to the recorded process.
4. It is model-independent and enabled with automatic conversion of recorded process to a data flow chart which can be plumbed to user-defined GUI.
5. Processes that could be automated include a) CAD, b) Meshing, c) Model Assembly, d)Morphing, e) Parameterization, f) Post-processing etc.

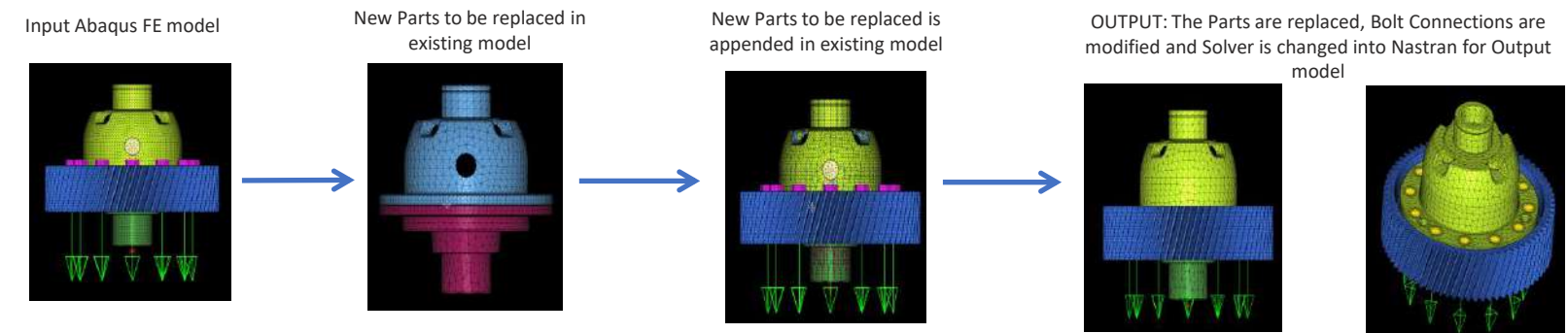
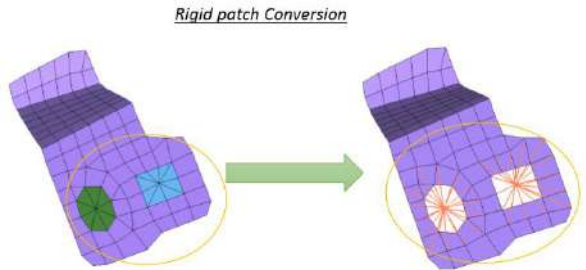

Uniqueness of MeshWorks

1. The PA creation is a simple recording of the entire process with 'on/off' recording options in MW. The entire recording automatically becomes the process and the data in the recording will become associated variables for the PA function.
2. The GUI creation can be done as the result of simple drag & drop actions done by the user and it doesn't need scripting in backend).
3. The linking of the backend process to the frontend user interface is done by 'Drag & drop' making it a quick/easy function interface creation method.
4. The MW PA is created with in-built flexibility to connect/integrate with external scripts like python and similarly MW PA's can be called from within external environment like TCL/TK (There is complete generality applicable PA functions).
5. A robust count of 60 Specialized Pre-packaged PAs are available in MW23 that act as Enabler Functions for user's tasks.

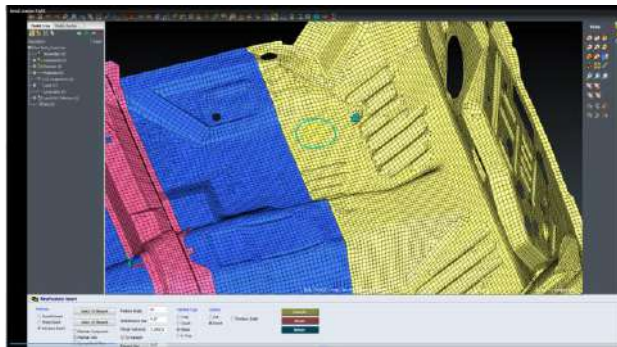

Step 1: Record the Advanced USER process using MSF.

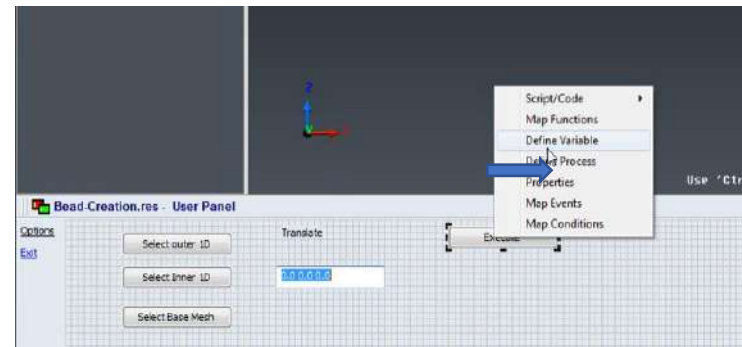

Step 2: Create a UI panel for variables.

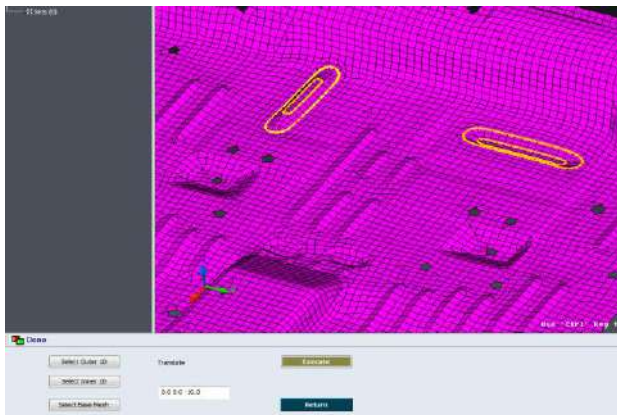

Step 4: Executing the function using process Auto User Panel

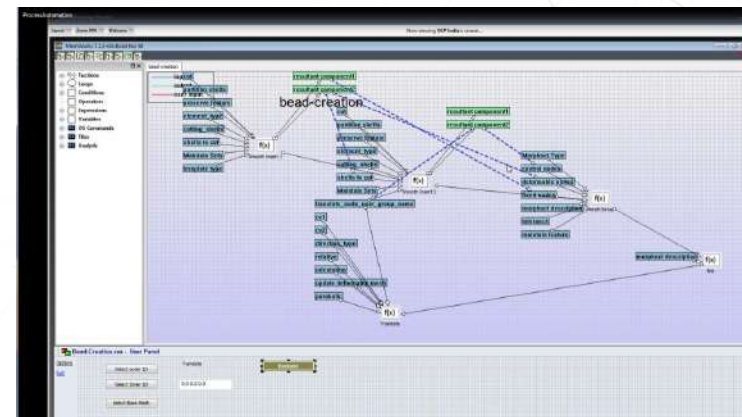



Step 3: Plumbing the Process with UI, and Publish the resource file.

NEW! Innovative ROM Module 

NEW! Productive Electrification Module 

Highly automated Process workflows 

Groundbreaking Concept Modeling 

Intelligent AI/ML CAE framework 

Next generation CAD/CAE Morphing 

Advanced Post processing 

Cutting-edge CAE parametrization 

Rapid Meshing & Modeling 

Time Saving MDO 



Value Proposition for MeshWorks Users

- Entire Concept parts and assemblies can be created with ZERO CAD opening up a new world of CAE assessment during early product development phase!
- Great time reduction – On average each member or joint can be created within 5 minutes ! A complete Automotive Body-in-White structure can be created within 1 calendar week by 1 person.
- Concept models generated using ConceptWorks take into account manufacturing feasibility principles thereby easy adoption for subsequent product development phases.
- Though tuned for concept stages of product development, the tools can be used at any stage of vehicle development – ideal CAE design.
- Very short learning curve, users are up and running within a few hours of training !! – no need for any special expertise.
- With special FE details such as fillets, draft angles, beads, ribs, stiffeners etc. the concept models have a very realistic design intent captured.

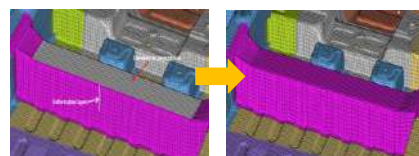

Adjustments

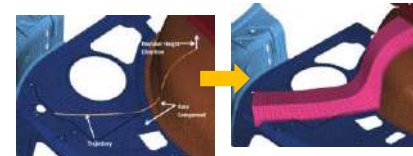

Member Creation

ConceptWorks

Groundbreaking Concept Modeling

- ConceptWorks module in MeshWorks redefines the concept modeling phase by giving CAE engineers the power to create CAE models with ZERO CAD!
- ConceptWorks has sub modules for a) Sheet Metal, b) Castings, c) Plastics, d) Extrusions & e) Additive Mfg. Parts & Assemblies at the concept stage of product development.
- A wide variety of tools for creating direct FE members are available such as: a) Tubular shell member using section & trajectories, b) Tubular shell member using multiple variable sections, c) Cast tubular member from sections, d) Shear panel member using sections and trajectories, e) Extruded members with variable cross-sections etc.
- A wide variety of tools for creating direct FE joints are available such as: a) Joints using 2 sections, b) Joints using 3 sections, c) Joints with overlap, d) Joints with direct flange connection, e) Blended Solid joints connecting sections etc.
- Special features are auto-generated with minimal user inputs into the concept FE model such as: a) draft angle, b) fillets, c) holes, d) beads, c) ribs etc.
- Besides creating parts & joints with ease ConceptWorks allows assemblies to be created accounting for interactions between parts.
- Connectors such as spot welds, seam welds, bolt connections, contact definitions, rigid connections etc. can be applied on the concepts models to create runnable assembly models.
- Concept FE models can be created using a pure design approach such as member width, depth etc. or alternately use topology optimization generated iso-surface.

BSO Inner Part Creation

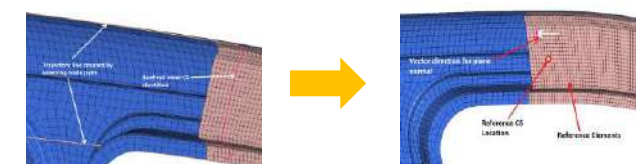

Uniqueness of MeshWorks

1. ConceptWorks module is a one-of-a-kind product that is an industry first – the ability to directly create concept FE models with ZERO CAD is unique to MeshWorks and cannot be found in any other product.
2. The technology has been patented which is testament to its uniqueness.
3. The comprehensiveness of CW module spanning several manufacturing processes such as sheet metal, castings, plastics, extrusions & AM can be found only in MeshWorks.
4. Compared to other CAD based approaches, Concept FE model creation in CW is extremely fast – for example, a complete automotive body FE model can be created by 1 person in 1 week using CW which otherwise would take 5 times more using other tools!!

Conventional to EV Conversion



Old Conventional Model

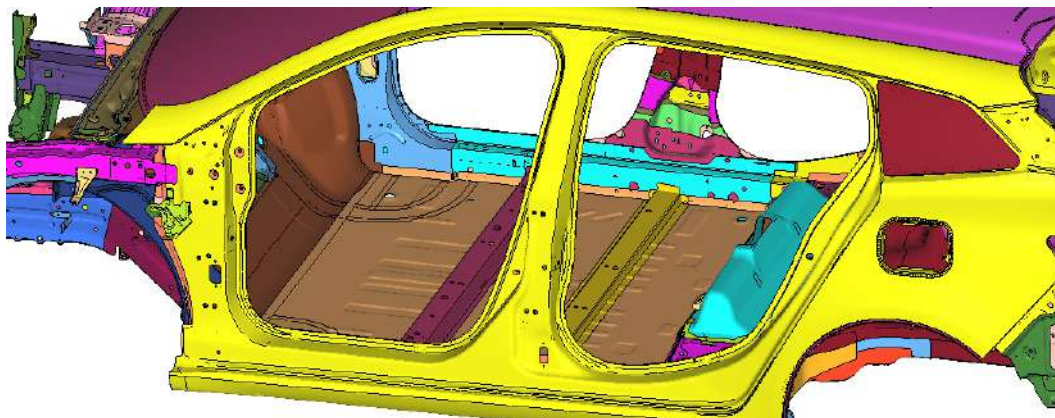

New EV Model BIW

Joint Creation

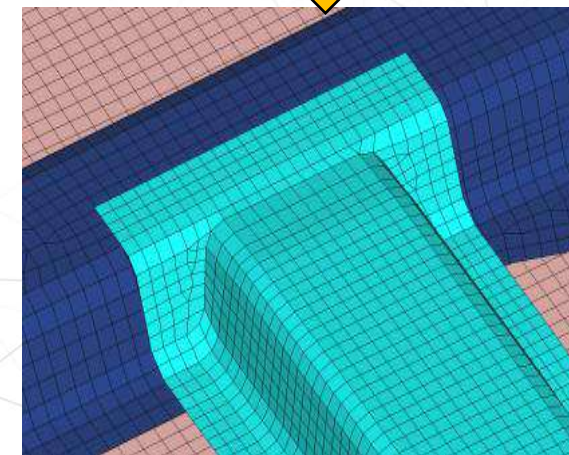
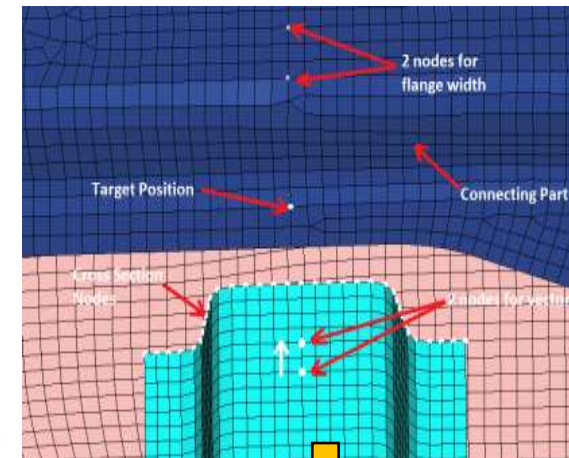

NEW! Innovative ROM Module

NEW! Productive Electrification Module

Highly automated Process workflows

Groundbreaking Concept Modeling

Intelligent AI/ML CAE framework

Next generation CAD/CAE Morphing

Advanced Post processing

Cutting-edge CAE parametrization

Rapid Meshing & Modeling

Time Saving MDO

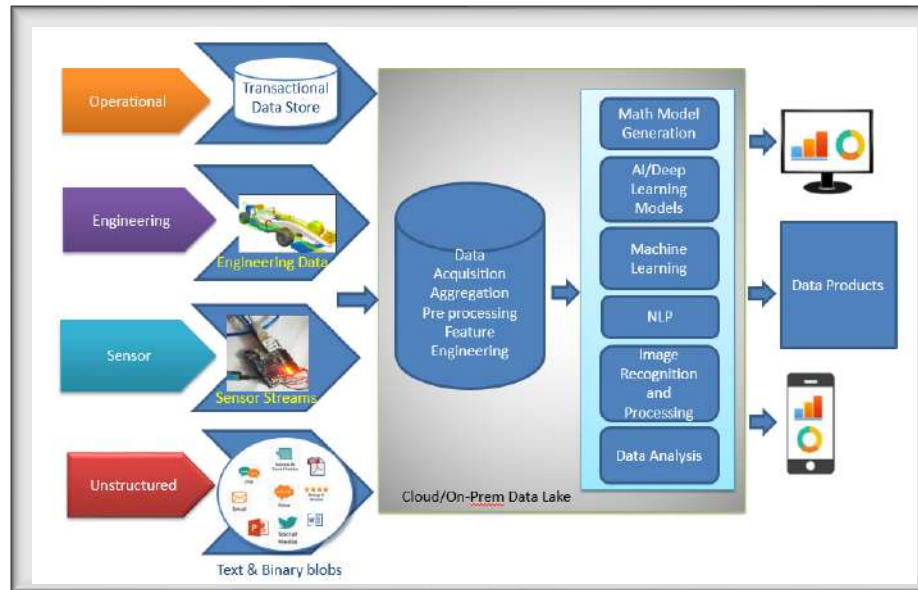

AI/ML Framework

Intelligent model creation technology

1. MeshWorks AI/ML technology is a framework comprising of a wide suite of algorithms/models involving neural network (CNN/DNN) models, approximation models, response surface models etc.
2. The models are adaptive and can be trained on customers' data on a continual basis.
3. The framework allows to fit different AI/ML models to different responses to get the best accuracy & prediction.
4. The framework then links the predictive models to parametric CAE models wherein the visual parameters are connected to output responses (for example an automotive rail cross-section to a crash pulse).
5. This linking enables users to create Design Advisor applications giving a visual experience between geometric changes and predicted responses instantaneously.
6. The framework can be applied for sensitivity, optimization studies as well in addition to creating Design Advisors.

Value Proposition for MeshWorks Users

1. Design Advisors with a visual interface enabled by MeshWorks AI/ML technology offer significant guidance during early stages of new product development.
2. Application of the right AI/ML model for the right output response greatly increases the predictive ability of the design advisors.
3. In-house expertise from available data can be institutionalized.

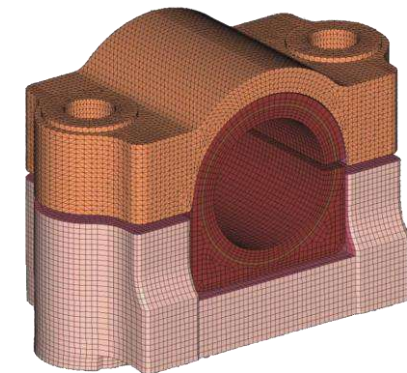
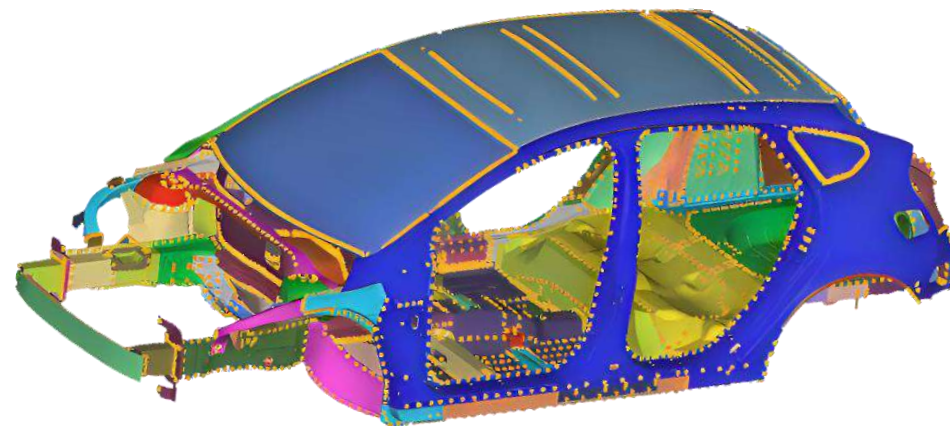

Uniqueness of MeshWorks

1. The link between parametrized geometric FE model to an underlying AIML model is the uniqueness of the AI/ML framework in MeshWorks.
2. Parametric CAE capability within MW also offers the unique capability to generate multi-sample data for customers who do not have extensive in-house data.

	A	B	C	D	E	F	G	H	I	J	K
1	Point	Bottom_Side_Width	Rear_Glas	Spoiler_Angle	Spoiler_He	Top_Side	Winglet_A	Rear_Heig	avg_drag	integral_icfd_drag	cx
2	sk	dv	dv	dv	dv	dv	dv	dv	rs	rs	rs
3	1	0.00E+00	0.00E+00	0.00E+00	0.00E+00	0.00E+00	0.00E+00	0.00E+00	-7.11E+02	-7.11E+00	6.61E-01
4	2	-2.77E-03	-3.64E-02	-1.76E+00	-4.34E-04	-1.06E-02	-5.85E-02	-5.71E-01	-7.10E+02	-7.10E+00	6.60E-01
5	3	-2.90E-03	4.95E-03	4.99E+00	2.70E-03	1.16E-02	1.99E-02	-6.00E-01	-7.38E+02	-7.38E+00	6.85E-01
6	4	-2.81E-03	-4.71E-02	4.71E+00	1.46E-02	1.72E-02	-5.75E-02	4.00E-01	-7.60E+02	-7.60E+00	7.06E-01
7	5	-2.89E-03	-4.96E-02	3.24E+00	1.36E-02	-1.72E-02	-4.16E-02	9.99E-01	-7.64E+02	-7.64E+00	7.10E-01
8	6	-2.95E-03	4.82E-02	2.90E+00	-1.61E-03	-1.99E-02	1.34E-02	-5.83E-01	-7.22E+02	-7.22E+00	6.71E-01
9	7	1.77E-03	-4.90E-02	-1.95E+00	1.47E-02	1.99E-02	-5.92E-02	9.65E-01	-7.28E+02	-7.28E+00	6.76E-01
10	8	1.79E-03	-4.85E-02	-1.78E+00	-6.93E-04	-1.95E-02	1.56E-02	9.70E-01	-7.22E+02	-7.22E+00	6.71E-01
11	9	2.97E-03	-3.82E-02	2.59E+00	-1.13E-03	-1.96E-02	-5.23E-02	-5.24E-01	-7.22E+02	-7.22E+00	6.70E-01
12	10	-2.62E-03	-4.84E-02	4.18E+00	3.20E-03	2.68E-03	1.95E-02	6.56E-01	-7.54E+02	-7.54E+00	7.00E-01
13	11	9.46E-04	4.76E-02	-1.73E+00	6.86E-03	-1.98E-02	1.55E-02	7.30E-01	-7.20E+02	-7.20E+00	6.69E-01
14	12	2.58E-03	4.97E-02	4.89E+00	1.44E-04	-1.94E-02	-1.72E-02	-5.89E-01	-7.30E+02	-7.30E+00	6.78E-01
15	13	-2.92E-03	4.18E-02	-1.32E+00	1.47E-02	-1.89E-02	1.37E-02	-3.21E-01	-7.14E+02	-7.14E+00	6.63E-01
16	14	1.67E-03	4.92E-02	-1.98E+00	-1.89E-03	-1.52E-02	-5.80E-02	-5.97E-01	-7.01E+02	-7.01E+00	6.51E-01
17	15	2.99E-03	-4.92E-02	-2.00E+00	5.36E-04	-2.00E-02	1.71E-02	-5.96E-01	-7.05E+02	-7.05E+00	6.55E-01
18	16	1.00E-03	-4.69E-02	4.98E+00	-2.45E-04	-1.06E-02	1.56E-02	-5.73E-01	-7.40E+02	-7.40E+00	6.87E-01
19	17	-1.59E-03	4.95E-02	3.15E+00	3.11E-03	-9.08E-04	-5.97E-02	-5.94E-01	-7.18E+02	-7.18E+00	6.67E-01
20	18	3.00E-03	-4.40E-02	-2.00E+00	1.50E-02	-1.61E-02	-5.99E-02	-6.00E-01	-7.05E+02	-7.05E+00	6.55E-01

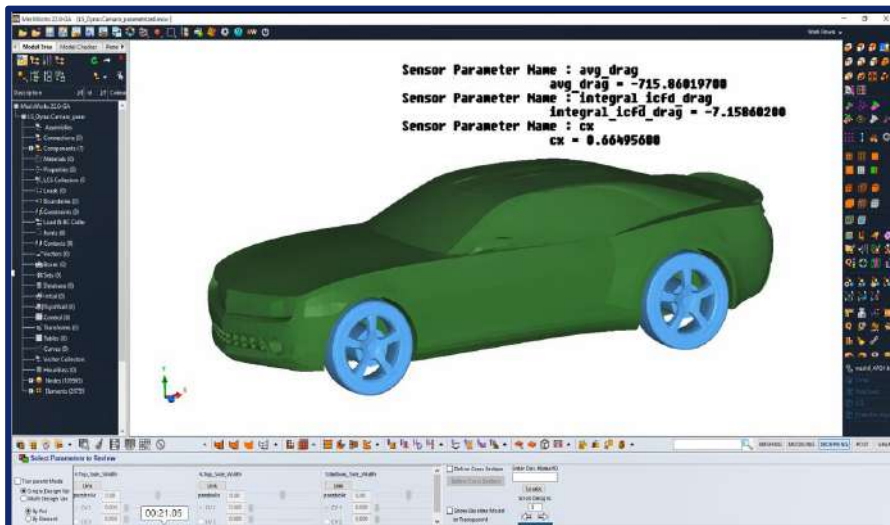

Data Extracted and saved in learning database

1



Appropriate AI/ML models get executed based on relationship of input and output responses

2



As input parameter changes in Design advisor, in real time output responses are computed by underlying AI/ML models and passed back to Design Advisor.

3

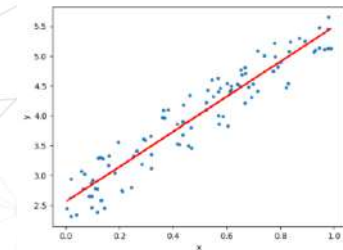
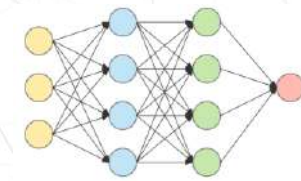



NEW! Innovative ROM Module 

NEW! Productive Electrification Module 

Highly automated Process workflows 

Groundbreaking Concept Modeling 

Intelligent AI/ML CAE framework 

Next generation CAD/CAE Morphing 

Advanced Post processing 

Cutting-edge CAE parametrization 

Rapid Meshing & Modeling 

Time Saving MDO 

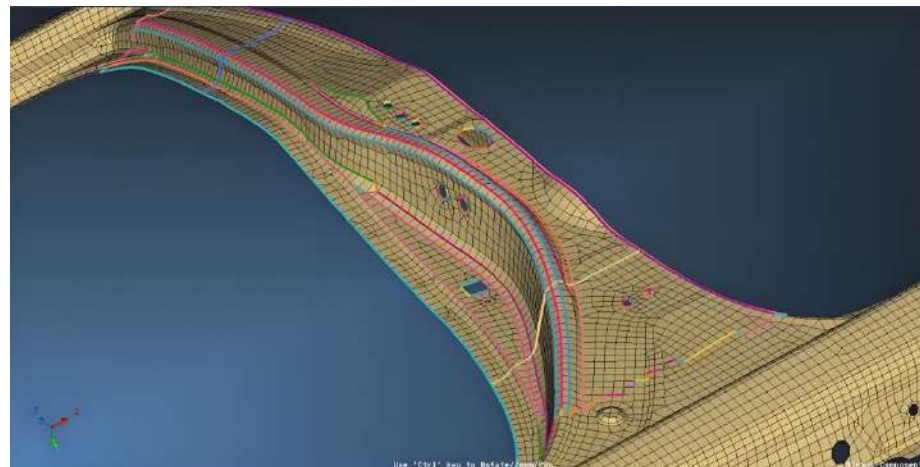

CAD/CAE Morphing

Next generation CAD Morphing

1. All morphing methods - old & new, the linking process and all transformation options have all been integrated under one single user interface panel. User experience tremendously improved with only one single panel.
2. Applicability of morphing methods expanded to several new transformation methods such as glide, overwrite etc.
3. Post operations such as remeshing, rewelding have been integrated into the morphing process.
4. The integrated approach to morphing allows users to one time morphing change or alternately make it as a parameter.
5. A powerful Section based morphing methodology added with which a part or assembly can be morphed by cutting sections and controlling the sections.
6. An equally powerful new Feature based morphing method has been added that gives the user the ability to reshape the parts & assemblies like clay with only feature lines.
7. AI/ML based morphing technology implemented to give a very intuitive feel.

Value Proposition for MeshWorks Users

1. The user should be able to achieve any new shape by treating the parts/assembly as if they were clay.
2. Zero thinking and planning needed even for very complex aspects of full system level morphing.
3. Models can be morphed within 100th of a millimeter precision.
4. Enormous control of features and sections during the morphing process.
5. Simple & intuitive user interface with very minimal learning curve - user needs to learn only one panel.
6. Significant time reduction compared to previous morphing techniques.
7. Truly Next Gen Morphing capability.

Uniqueness of MeshWorks

1. The ability to reshape a model with minimal to zero set-up by controlling its features and sections, the user does not have to figure out control, deformable, fixed zones etc.
2. The user selects only the region to morph, the tool gives the user the ability to reshape the region very intuitively & directly.
3. Complete controllability is possible during the morphing process such as preserving geometric features, crosssections, freezing features etc.
4. Precision of morphing - source to target matching can be within a hundredth of a millimeter or less.
5. The ability to preserve relationship between parts and assembly during morphing - automatic part stack-up adjustment & assembly structure maintenance.
6. The features of part or assembly can be morphed on the fly and the underlying shell or solid structure will automatically update to the morphed features.
7. Adaptive learning AI/ML technology behind the morphing engine.

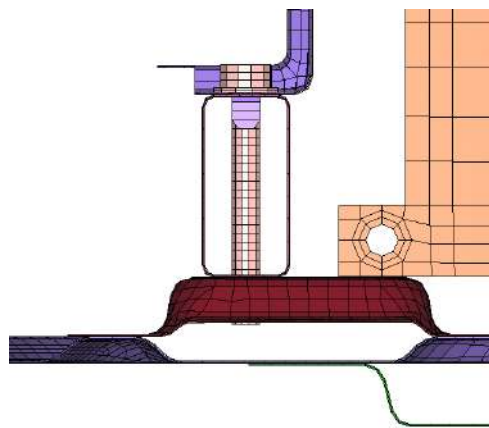
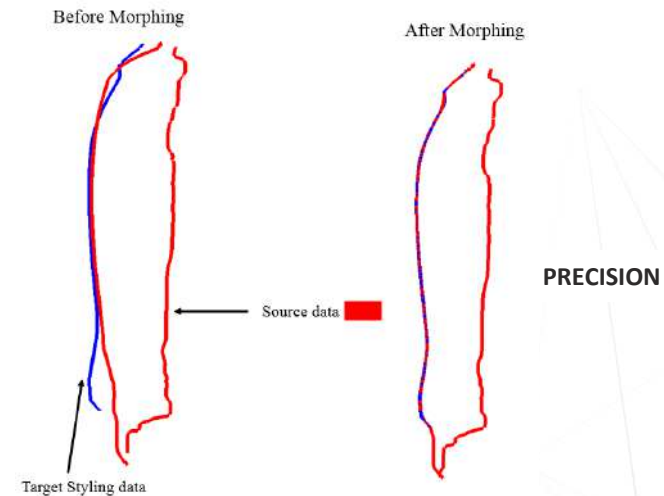
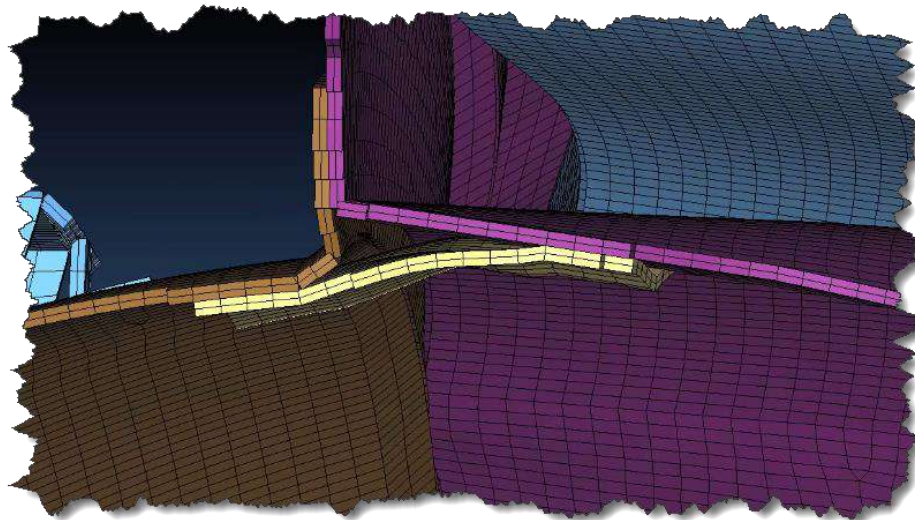

Min Design

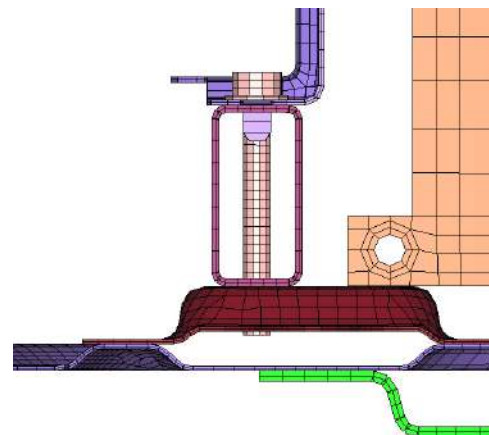

Baseline Design

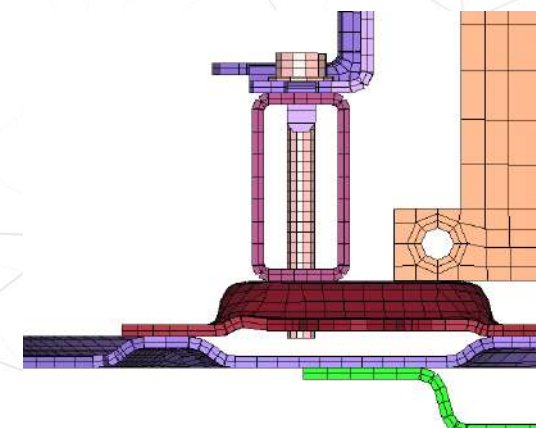

Max Design

NEW! Innovative ROM Module



NEW! Productive Electrification Module



Highly automated Process workflows



Groundbreaking Concept Modeling



Intelligent AI/ML CAE framework



Next generation CAD/CAE Morphing



Advanced Post processing



Cutting-edge CAE parametrization



Rapid Meshing & Modeling



Time Saving MDO

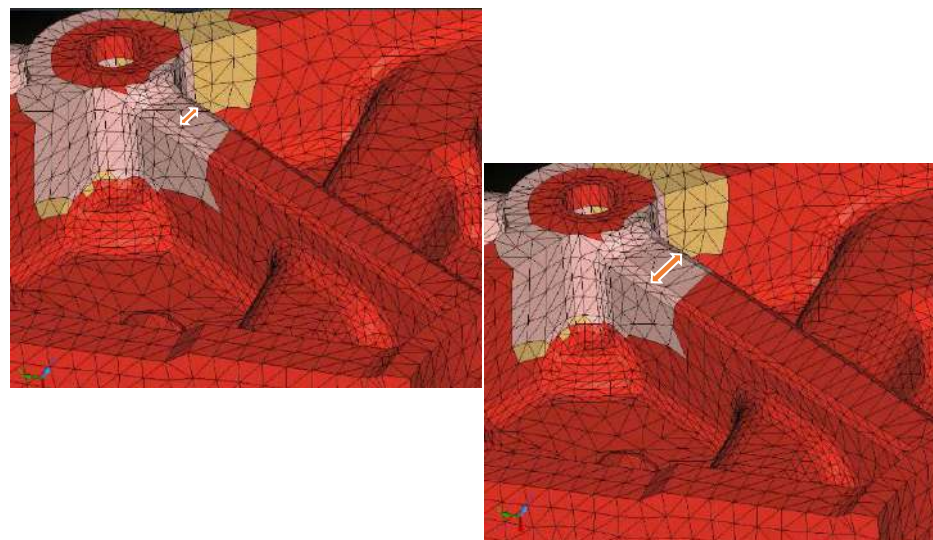
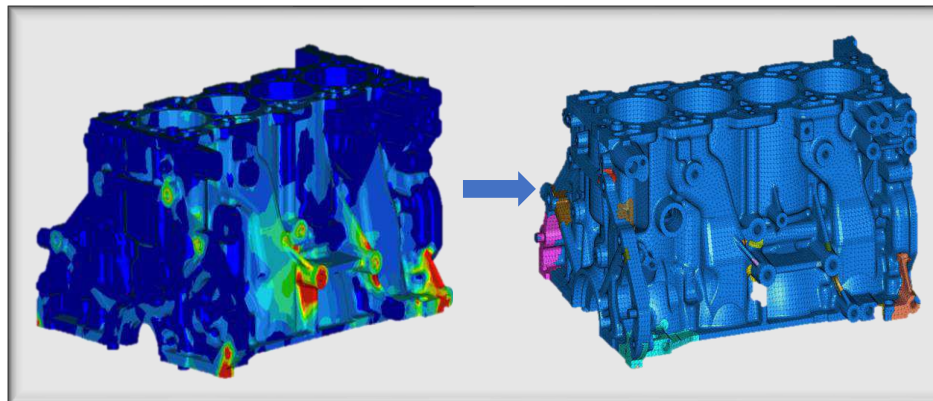

Advanced Post Processing

Rapid design exploration & optimization

1. MeshWorks has a multi-disciplinary post-processor for viewing and publishing the results of analysis. The post processor has in-built features that helps in design improvements.
2. The results derived from MeshWorks Post Processor has direct impact on design optimization process. This has been facilitated through the Post processor functions aimed to provide the design modification inputs (HotSpot Extractor). Using these inputs user can do shape changes making rapid design iterations.
3. Design Solutions: Design Enablers, Shape Parametrization, Cross rib and Honey comb, Tet rib.
4. Post-processing module in MeshWorks, provides a rich set of Industrial Standard post processing functionalities such as animations, contouring, cut sections and ISO plotting of results and many more such powerful features.
5. It also comes with an easy-to-use graphing module.
6. MeshWorks post processor has high degree of automation in all of its processes, for example- hot spot execute function, robotically detects hot spot regions in the analysis model and unionizes all the hotspot regions to the host model.
7. With the use of robust tools in MeshWorks Post Processor designers can do comprehensive study of their models & its effects.

Value Proposition for MeshWorks Users

1. Processes facilitated by MeshWorks Post Processor is Fast/accelerated from a user experience and ease of use perspective for all levels of users.
2. Our post processor function is designed in 'Industrial-grade' so that the resultant models are able to support develop manufacturable designs.
3. Using MeshWorks Post Processor, user can circumvent CAD & directly propose & develop the design solution at the FE Level itself saving lot of time in the conventional design cycle. Enormous control of features and sections during the morphing process. Ultimately, supporting users do design changes/ design improvement at a record short time.
4. User can improve the Baseline design in a very short time compared to the competition.
5. Each and Every one of the function in MeshWorks is highly automated and quick.
6. User can completely start with CAD and find solutions in FE level.

Uniqueness of MeshWorks

1. MeshWorks Post Processor function works for both component & full-vehicle models, and the automated post-processing features help in fast design iteration for both models.
2. The integrated Post processor approach, provides a direct path from post-processing results to design impact study. (Hot Spot extractor & unionizing the same which connects to design iteration).
3. The Auto Parameterization option available in the post processing toolkit helps to decide the various parameters to be created/modified to optimize the mass/performance of the model.
4. Integration of Pre and Post together in one Environment is unique in MeshWorks.
5. Based on the components that are analyzed in the MeshWorks Post Processor, various design changes are proposed. User can pick their preference for implementing them from the Solutions' array available in MeshWorks.
6. All the Functions that are available in MeshWorks will give user the ability to create new features in an existing design across Sheet metal, Plastics, Casting Parts.
7. With all the wide verity of fast design modification tools user can use it as a one time design Change or can create Parameters and link it in a Optimization.

- All the Functions that are available in MW23 will give user the ability to create new features in an existing design across Sheet metal, Plastics, Casting Parts.
- With all the wide verity of fast design modification tools user can use it as a one time design Change or can create Parameters and link it in a Optimization.
- Integration of Pre and Post together in one Environment is unique in MW23.

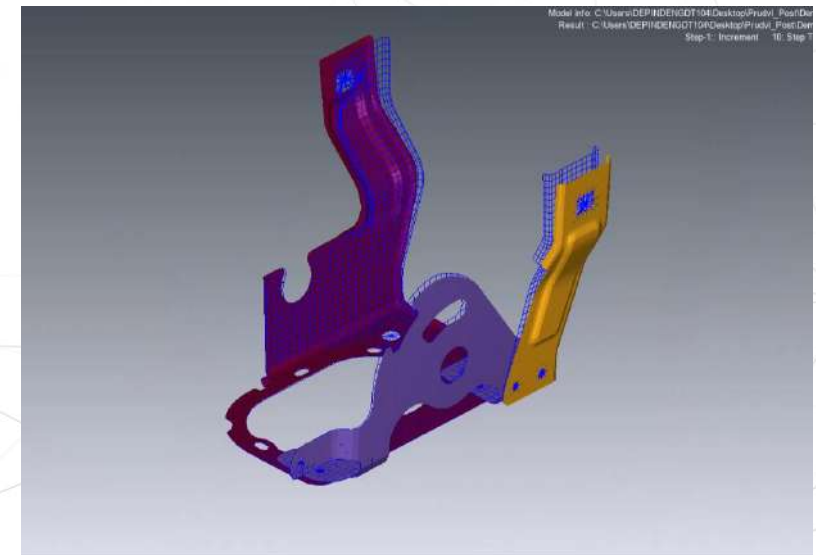
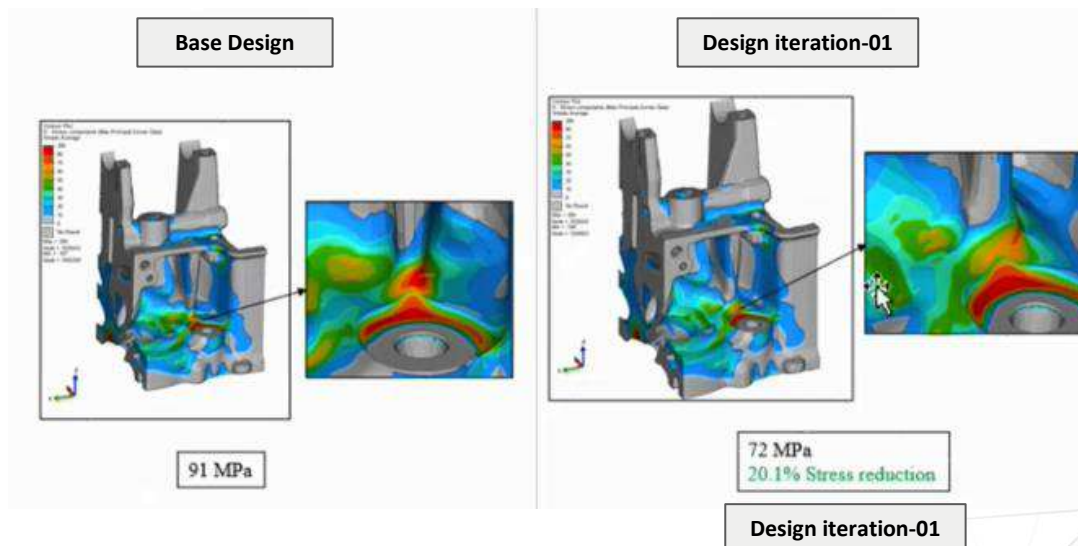
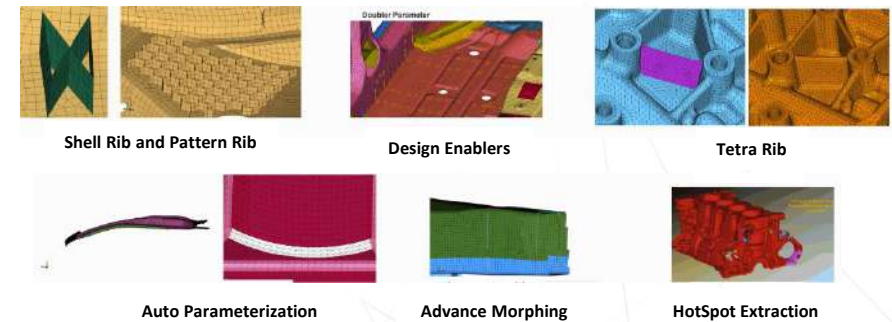

NEW! Innovative ROM Module



NEW! Productive Electrification Module



Highly automated Process workflows



Groundbreaking Concept Modeling



Intelligent AI/ML CAE framework



Next generation CAD/CAE Morphing



Advanced Post processing



Cutting-edge CAE parametrization



Rapid Meshing & Modeling



Time Saving MDO

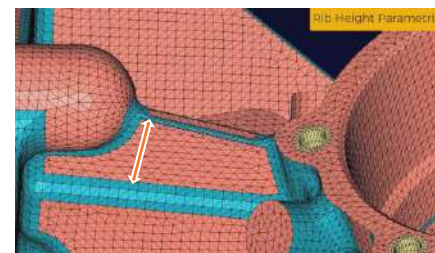
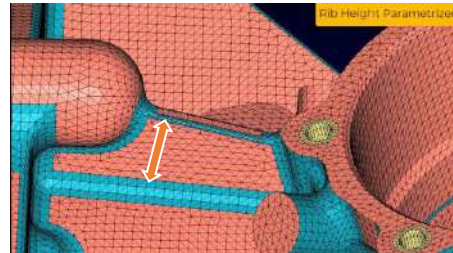
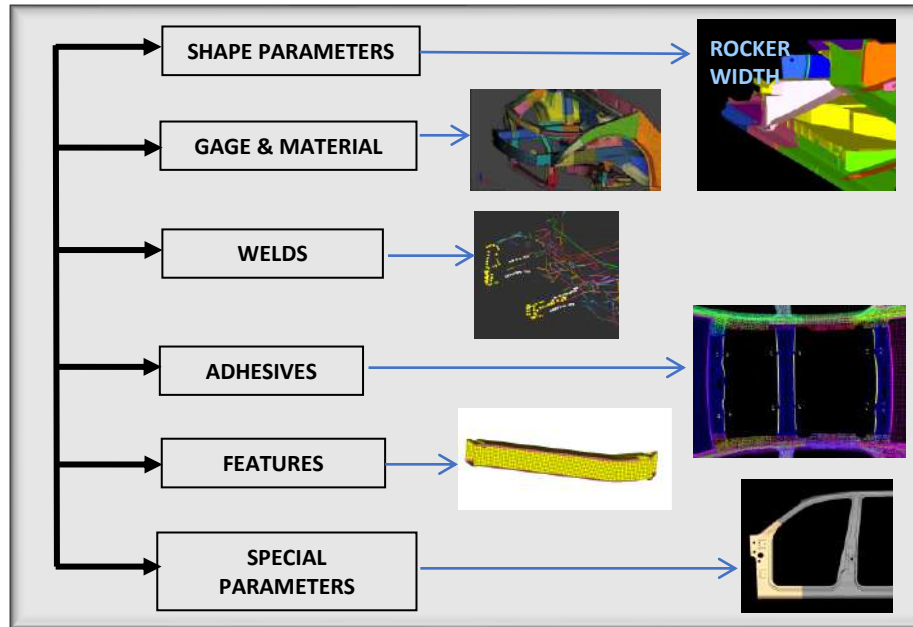

Value Proposition for MeshWorks Users

1. The widest range of parametrization in MeshWorks offers the widest design space which maximizes optimization potential.
2. The widest range of parametrization coupled with Multi-Disciplinary Optimization (MDO) offers the most weight reduction benefit while meeting performance targets.
3. The ROM (Reduced Order Modeling) module coupled with parametrization enables truly fast optimization.
4. The ease of parametrization reduces the overall time dramatically for fast design iterations and MDO.

CAE Parametrization

Cutting edge technology for parametric models

1. MeshWorks is a comprehensive CAE model parameterization engine with a broad range of categories of parameters that can be used at all stages of product development. Categories of parameters include: gauge, shape, sections, spot weld pitch, seam-weld-spacing, adhesive length, topology (member repositioning), features (number of holes, ribs, bulkheads, crush initiators etc. in a given space) and general parameters.
2. Regular FE/CFD models can be converted to intelligent parametric FE/CFD models. The framework allows to fit different AI/ML models to different responses to get the best accuracy & prediction.
3. The parameters can be exercised as one-time execution or linked to Design of Experiments (DOE) and Multi-Disciplinary Optimization (MDO) schemes.
4. Multiple runnable CAE models (literally hundreds of them) can be generated automatically by exercising the parametric CAE models.
5. Shape parameters can be created in a simple direct way with the Next Generation feature based and section based methodologies.
6. The Design Enablers can be executed as an integrated solution complete with properties, materials, connectors etc.
7. MeshWorks Parametric CAE engine is the most comprehensive that is out there which can also be applied across multi-disciplinary CAE models such as Crash, NVH, Durability etc.

Uniqueness of MeshWorks

1. MeshWorks offers the most comprehensive categories of parameters compared to any CAE software that is in the market.
2. The ease with which all the parameters can be created is a unique distinguishing feature of MeshWorks.
3. Depth of parametrization available in MeshWorks factors in the intricacies of gage change, stack-up adjustment, weld dependencies on gage changes - all coupled with other parametric changes - unique feature.

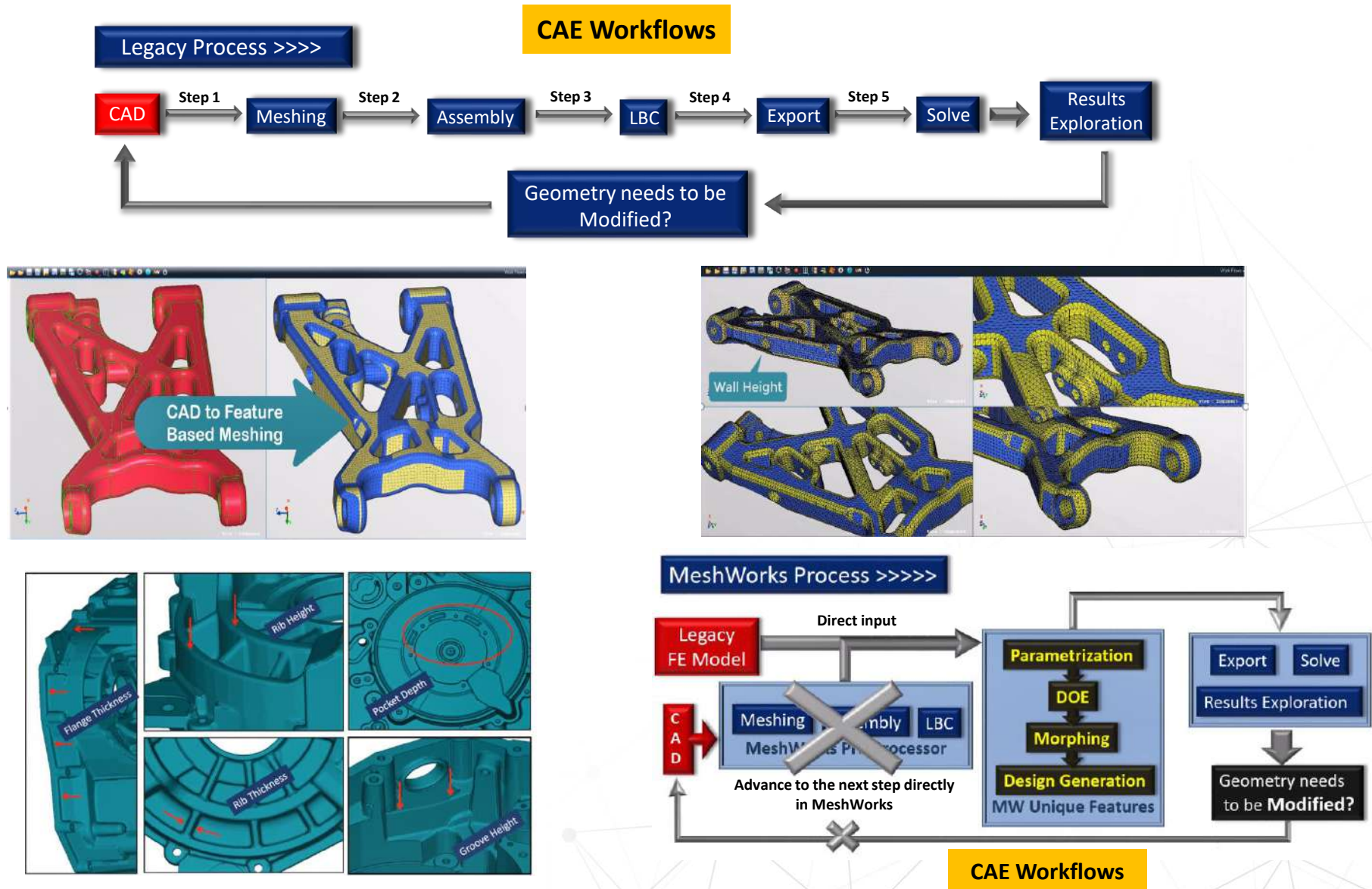

NEW! Innovative ROM Module

NEW! Productive Electrification Module

Highly automated Process workflows

Groundbreaking Concept Modeling

Intelligent AI/ML CAE framework

Next generation CAD/CAE Morphing

Advanced Post processing

Cutting-edge CAE parametrization

Rapid Meshing & Modeling

Time Saving MDO

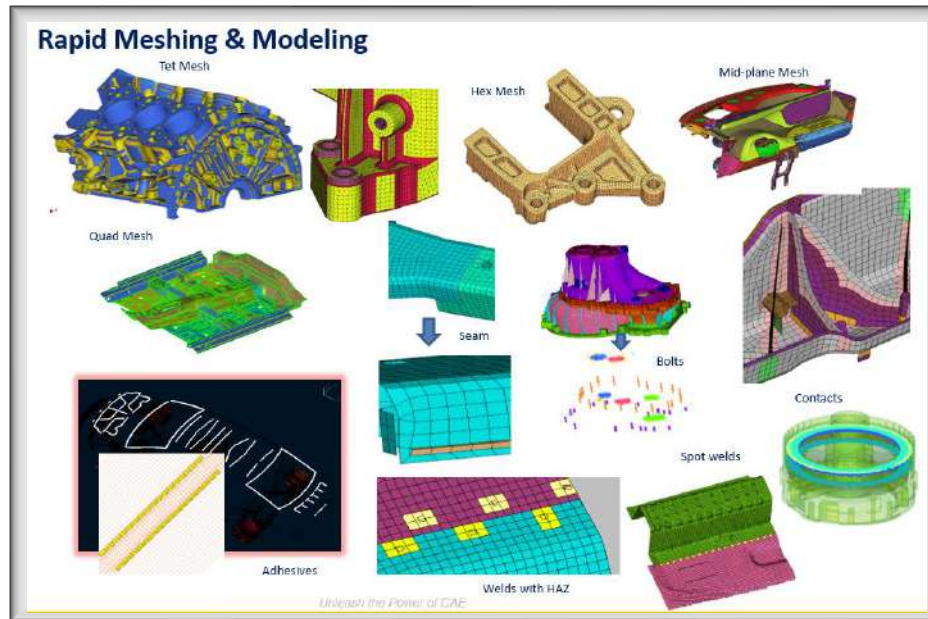

Value Proposition for MeshWorks Users

1. Significant improvement in CAD Clean-up which in turn reduces the time required for post mesh correction drastically.
2. Element quality is improved significantly compared to other tools in the market - again reduces meshing TAT (turn-around-time) in a big way.
3. All types of superior meshing under one roof - tetra, hexa, plastics, sheet metal etc.
4. Significant cost & time benefits - no need for multiple software for meshing.
5. The total meshing time is reduced by 30% to 50% across various types without compromising on mesh quality.

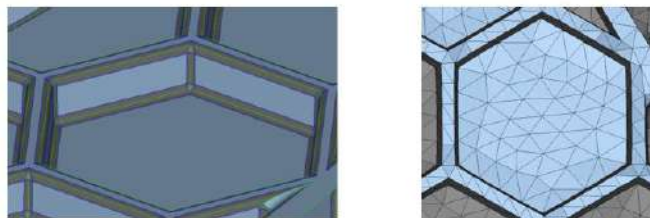

Peak Material Meshing

Meshing and Modeling

Rapid Meshing & Modeling

1. MeshWorks has a powerful CAE meshing engine that allows users to create 2D and 3D meshes rapidly from complex CAD data - Tetra, Sheet Metal, Mid-plane & Hexa.
2. Highly automated meshing functions available creating exceptional quality meshes with minimal to no CAD clean-up..
3. MeshWorks generated models produce higher geometric accuracy due to its comprehensive AI/ML based feature recognition engine.
4. Enormous mesh control is facilitated due to the template driven meshing in MW for features like Fillets, Tubes, Chamfers, Machined Faces, etc.
5. Powerful feature Removal & suppression tools to remove features like Fillets, Ribs, Bosses, etc. allow users to create simplified meshes for specific CAE workflows.
6. The Design Enablers can be executed as an integrated solution complete with properties, materials, connectors etc.
7. MW has the widest range of Hex meshing functions such as auto-cartesian-hex mesher, parametric extrusion hex mesher etc.

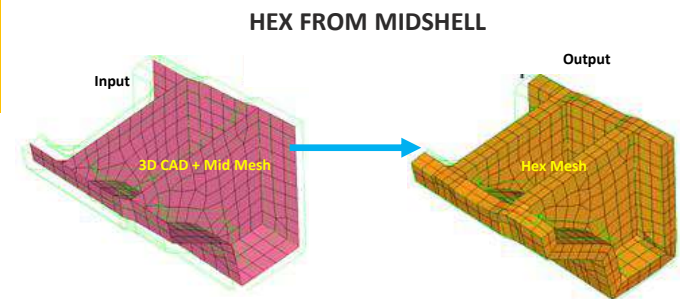

Uniqueness of MeshWorks

1. Tetra: MeshWorks rightly strikes the balance between feature capturing and automated meshing with good gradation control in skin mesh as well as in the tetra mesh level. This helps the user to produce the model with as minimal elements as possible.
2. Hexa: Majority of hex mesh functions such as auto-cartesian hex mesher, hex-fuse that joins two hex meshes with node-to-node connectivity, hex-cutter or hole driller etc. are found ONLY in MW.
3. Mid-plane: Several checking & verification functions such as adherence to the geometry, nodes outside or inside boundary, how to correct any deviations etc. are unique to MW.
4. Sheet Metal (Quad): Advanced AI/ML based edge suppression algorithm produces best mesh flow with enormous mesh control.
5. Using CAD-Mesh compare user can easily reuse existing mesh for matching geometric regions.
6. With the help of Highly Advanced thickness assignment tool variable thickness assignment achieved with high accuracy.
7. MW has a wide variety of Specialized hexa modeling tools like Tire Modeling, Gear modeling, Rotor modeling etc. which are unique and highly automated.

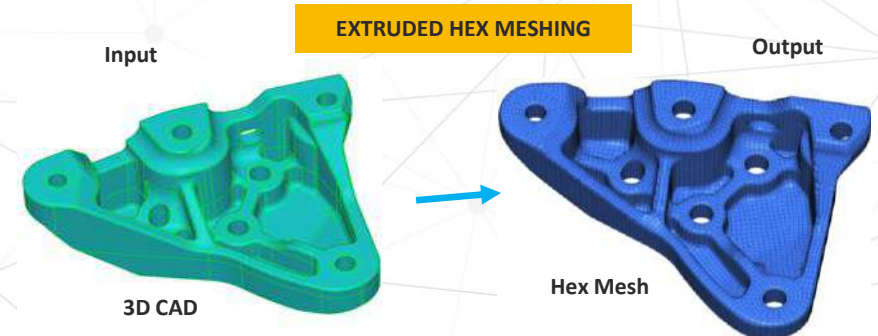
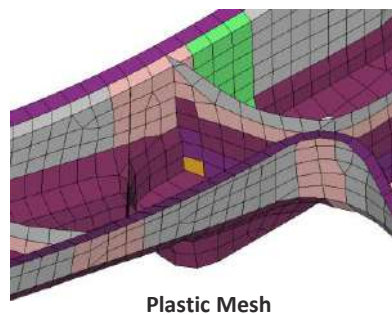
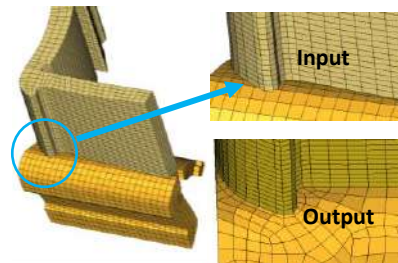
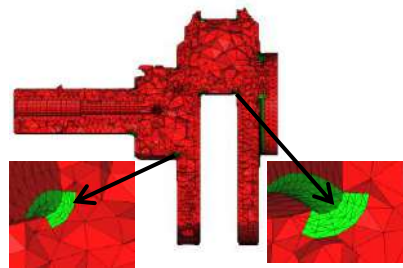
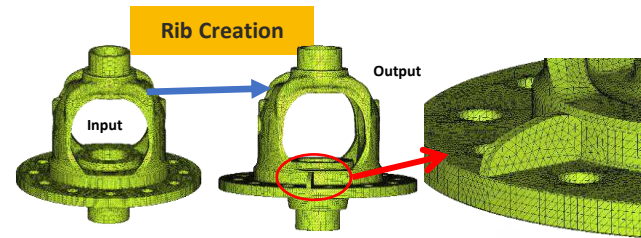
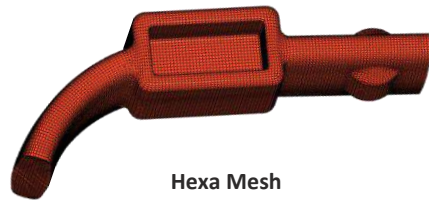

NEW! Innovative ROM Module



NEW! Productive Electrification Module



Highly automated Process workflows



Groundbreaking Concept Modeling



Intelligent AI/ML CAE framework



Next generation CAD/CAE Morphing



Advanced Post processing



Cutting-edge CAE parametrization



Rapid Meshing & Modeling



Time Saving MDO

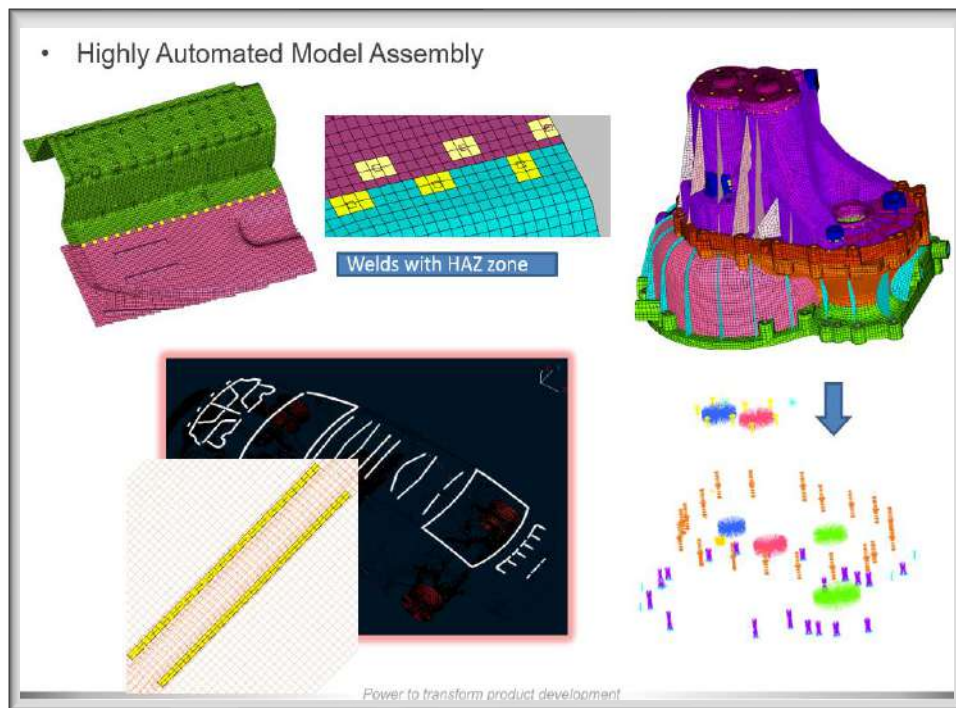

Meshing and Modeling

Rapid Meshing & Modeling

1. MW has the widest variety of model assembly functions - Seam welds, Spot Welds, Adhesives, Bolt Connections, Contacts, etc
2. Within each category of connections tremendous depth is available with variations to the connection - for example: solid bolt, 1D bolt, rigid bolt connections.
3. All connection creation functions are fully or highly automated.
4. MW assembly functions comprehensively address: sheet metal assemblies, cast/machined component connections, plastic assembly connections etc.

Value Proposition for MeshWorks Users

1. MeshWorks features being highly automated can save a lot of time during model assembly process.
2. The ability to Co-Create, when creating a bolt assembly, we not only create the 3D bolts, but we do co-create the contacts & pre-tension simultaneously. (Connecting the dots process).
3. Weld Optimization Possibility - Reduce the no. of seam welds & spot welds, reduce weld length, adhesive length, etc. (Manufacturing cost reduction through parametrization of connectors).
4. High fidelity of modeling (Like HAZ Modeling) results of analysis will have higher and better accuracy.
5. Upto 60 % of time can be reduced. As the tool is user-friendly and requires very minimal inputs to perform the function thus requires only minimal training.

Uniqueness of MeshWorks

1. During early stages of design/dev. connector data may not be available. MW has the ability to auto generate connectors. MeshWorks detects gaps between mating parts and generates weld lines (Seam & Spot), bolt connections etc.
2. 3D Bolt creation - bolt mesh can be auto-generated even if no bolt geometry is available.
3. Ability to parametrize connectors (Ex- Weld Length, Spot weld pitch, length of seam weld lines, skip welds, etc.) & optimize them subsequently for manufacturing cost reduction.
4. MeshWorks facilitates Parametrization as an assembly across different connector types and associated parts (For example: Bolt along with bosses are moved together as a parameter).
5. Contacts Management - Auto contacts creation, Ex- Shell to solid, Solid to solid, Shell to shell (throw an entire assembly of parts, MeshWorks can automatically create the connections).
6. Ability to detect auto closure, shell gap, over closure etc. for Contacts.
7. Depth of the connection creation: Ex: HAZ (Heat Affected Zone) modeling for sheet metal & solid structures.
8. When converting the model to diff. disciplines, MW automatically converts the connectors to appropriate representations.
9. Ability to morph the connectors as a geometric feature.

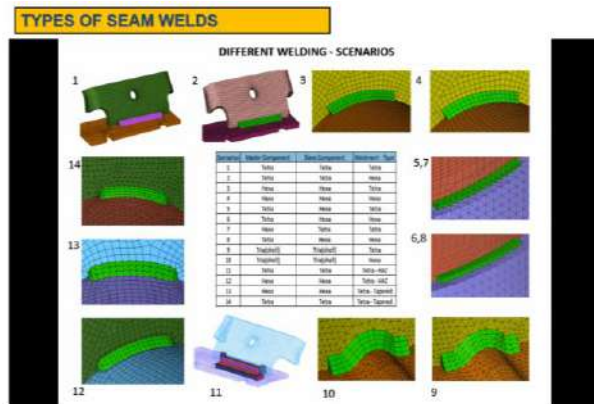
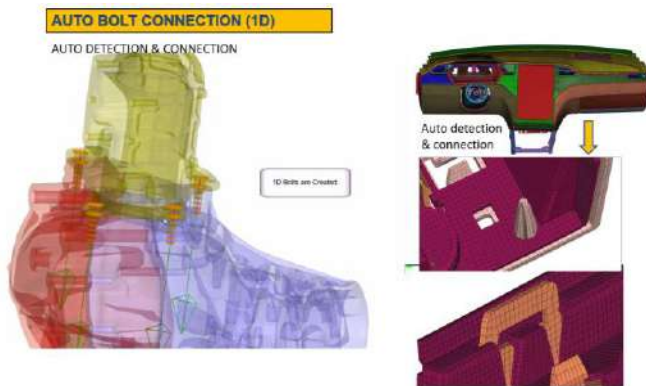

Process Automation: Sub-frame - Automatic Template Based Meshing & Assembly

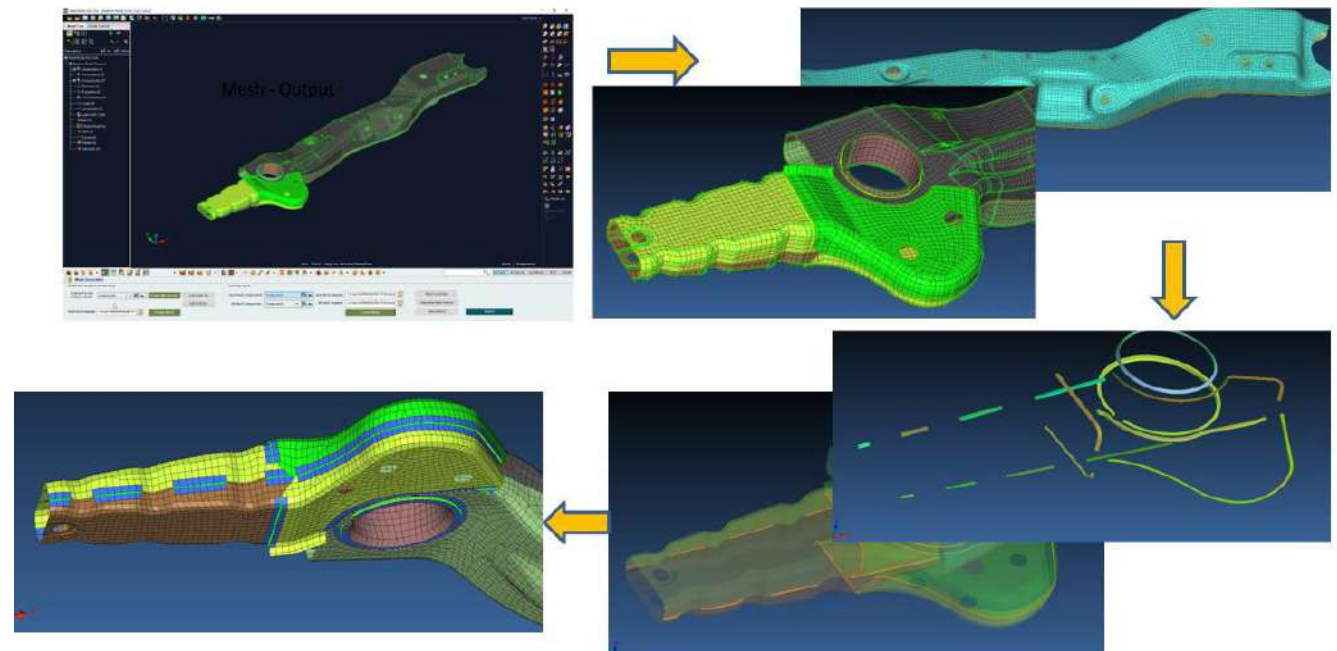

NEW! Innovative ROM Module



NEW! Productive Electrification Module



Highly automated Process workflows



Groundbreaking Concept Modeling



Intelligent AI/ML CAE framework



Next generation CAD/CAE Morphing



Advanced Post processing



Cutting-edge CAE parametrization



Rapid Meshing & Modeling



Time Saving MDO

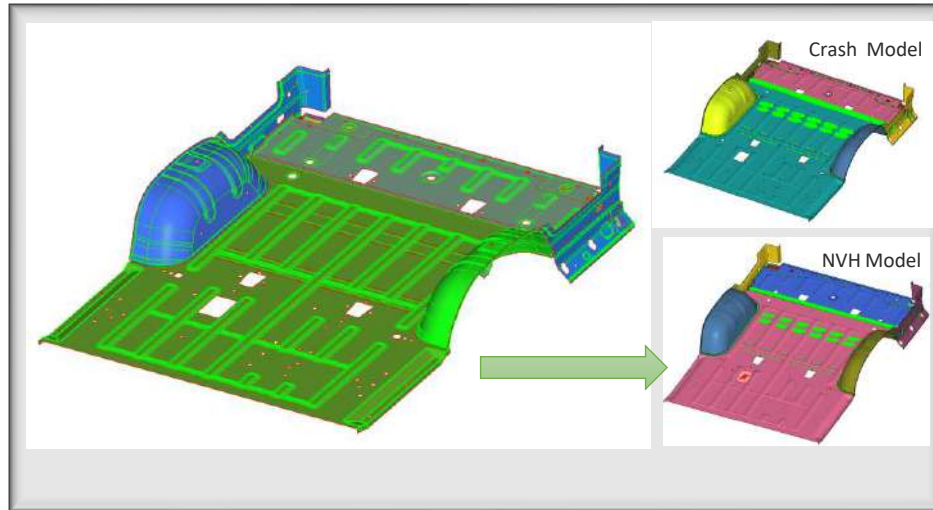

Value Proposition for MeshWorks Users

- MW based MDO Optimization process enables the achievement of Weight & Cost targets, while maintaining a balanced performance across multiple disciplines.
- Integrating Reduced Order Model (ROM) approach to MDO in MeshWorks can significantly reduce analysis run time and hence MDO turnaround time.
- MeshWorks MDO follows an inclusive methodology that incorporates Manufacturing, Packaging, Human factors and other Design aspects along with Structural considerations resulting in a balanced optimization.

Multi-Disciplinary Optimization

Time saving MDO empowered by Parametric & Morphing Technology

- MeshWorks-based Parametric and Non-Parametric CAE models are a key enabler for Multi-Disciplinary Optimization (MDO). These parametric models make MDO efficient and an everyday process.
- Parametrization in MeshWorks saves significant time and effort for each discipline analysis (Crash, NVH, Durability, CFD etc.), as the parameters created for one discipline can be quickly transposed onto other discipline models.
- Additionally, MeshWorks allows for the generation of multiple analysis datasets based on a Design of Experiments (DOE) matrix, enabling nominal and robust optimization studies.
- The MDO process is significantly accelerated using parametric Reduced Order Models (ROM) built in MW. This saves significant analysis run time and effort, while still producing reliable results.
- In summary, the use of MeshWorks-based Parametric and Non-Parametric CAE models has transformed the MDO process, allowing for efficient and robust optimization studies to meet design targets, minimize product weight and manufacturing costs, and save valuable time and effort in the analysis phase.
- The integration of parametric ROM approaches further enhances the optimization process, enabling rapid and accelerated studies for optimal design solutions.

Multi Disciplinary Optimization



Same Control Block and Parameters used for Multiple Disciplines to get Precise Optimized design in all aspects

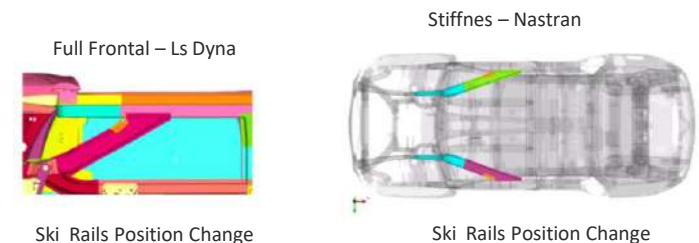

Ski Rails Position Change

Ski Rails Position Change

Uniqueness of MeshWorks

1. Highly automated transposing of parameters from a master models to other discipline models is a unique feature of MW.
2. MeshWorks offers the widest range of parameters for diverse problems maximizing the design space and hence the extent of optimization.
3. Parametric Reduced Order Model (ROM) techniques is unique to MW.
4. Seamless integration with major optimization software such as Isight, ModeFrontier, Heeds, Optimus, LS-Opt, and others enhances workflow efficiency.

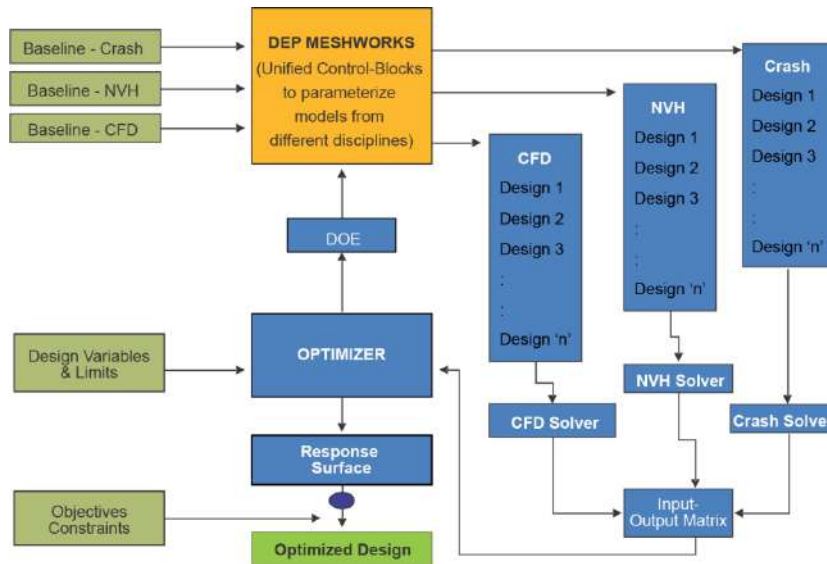

COMPREHENSIVE PARAMETRIZATION

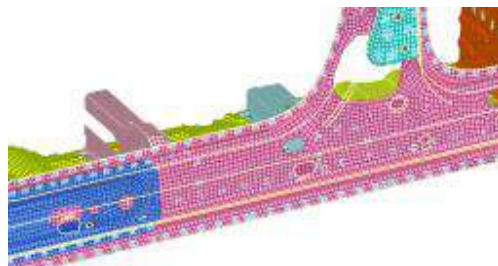
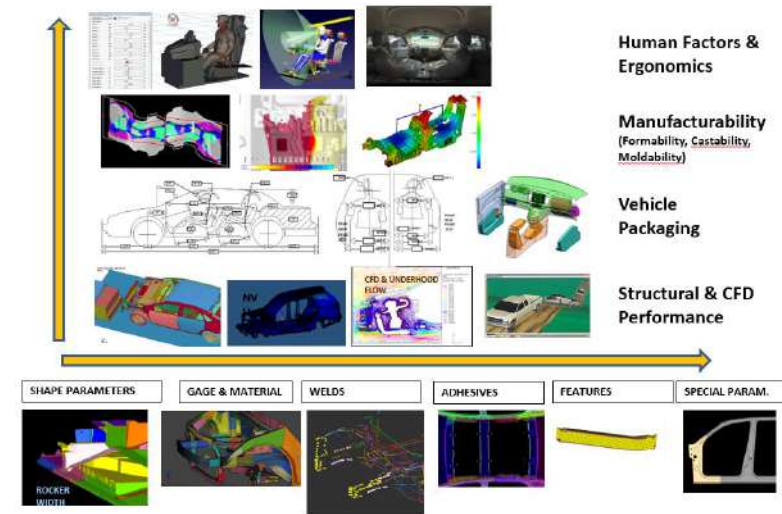

Bulkhead created

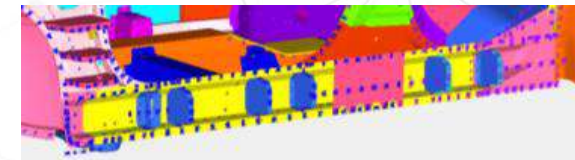
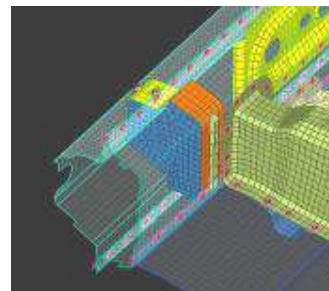



BIW / Chassis: Bulkhead creation – Location and Number of bulkheads can be a parameter. No CAD required

NEW! Innovative ROM Module 

NEW! Productive Electrification Module 

Highly automated Process workflows 

Groundbreaking Concept Modeling 

Intelligent AI/ML CAE framework 

Next generation CAD/CAE Morphing 

Advanced Post processing 

Cutting-edge CAE parametrization 

Rapid Meshing & Modeling 

Time Saving MDO 

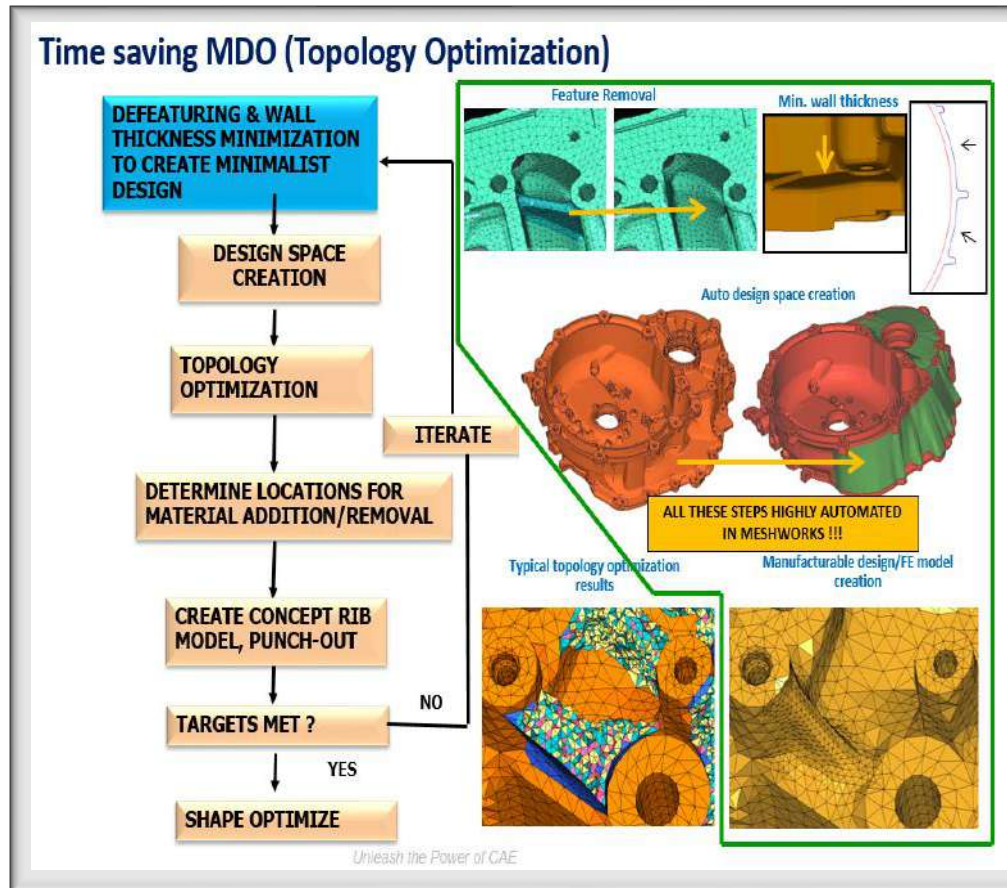

Topology optimization

Part of MDO

1. MeshWorks is a Pre and a Post processor for topology optimization process work flows.
2. As a pre-processor, MeshWorks enables the users to de-feature locations of ribs and bosses in complex geometries.
3. One can create minimalistic design using morphing approach on component level as well as a full vehicle level considering manufacturability criteria for castings, extrusions, stampings etc.
4. User can create design space on the minimalistic design in a highly automated fashion. MeshWorks has several automated Concept FE model creation functions representing the load paths suggested by Topology optimization results.
5. The user has the ability to create alternative design suggestions like ribs, new members, joints etc. besides increase or decrease wall thickness as suggested by load paths.
6. Creation of new parts from scratch or reinforcements like doublers and bulkheads representing load paths is highly automated. MeshWorks can handle such topology optimization post processing at a component as well as a full system level.

Value Proposition for MeshWorks Users

1. MeshWorks 'Minimalistic design Topology Optimization' approach yields maximum weight reduction compared to any other optimization process flow.
2. Tremendous time reduction in pre and post-processing since most of the functions are highly automated.
3. MeshWorks workflow skips the CAD designer completely in creating valid concept FE model directly from the topology results, thus resulting in tremendous time saving.
4. MeshWorks has the complete set of tools to handle both component and assembly level design changes. The tools are also capable of handling components falling under different manufacturing processes like castings, extrusions and stampings.

Uniqueness of MeshWorks

1. Quick feature removal tool that can handle complex geometries.
2. Ability to create body fitted design space with high degree of automation.
3. Ability to convert a full system ISO surface model to a beam model.
4. Availability of advanced Concept FE tools such as members, joints, ribs, doublers, bulkheads etc. for castings, stampings, extrusions and plastics.

CARVED OUT TOPOLOGY

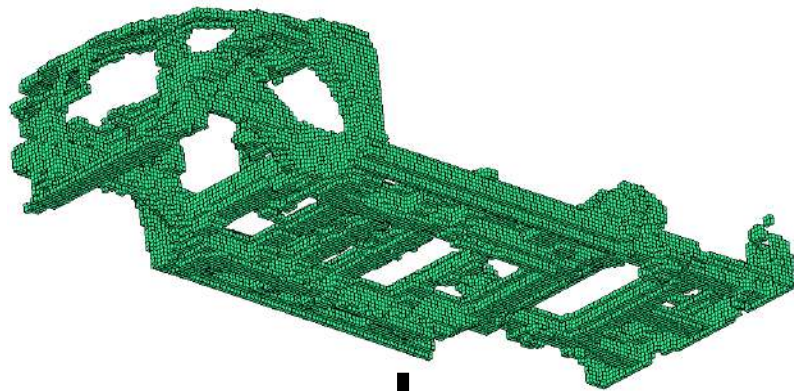

DEP's RAPID MODELING TECHNOLOGY

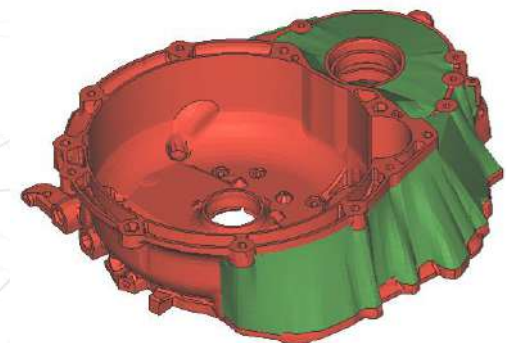
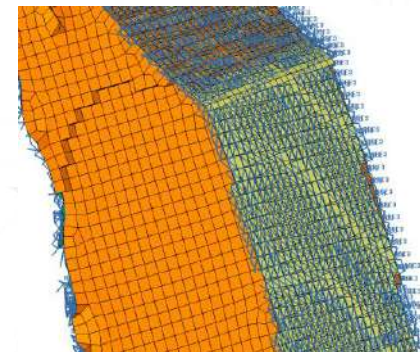
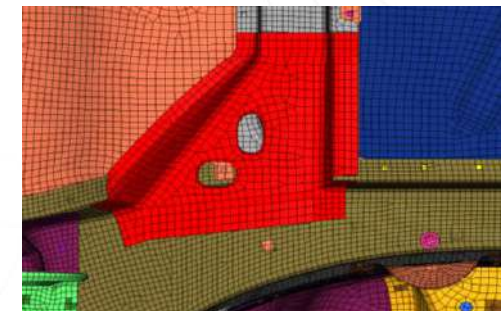
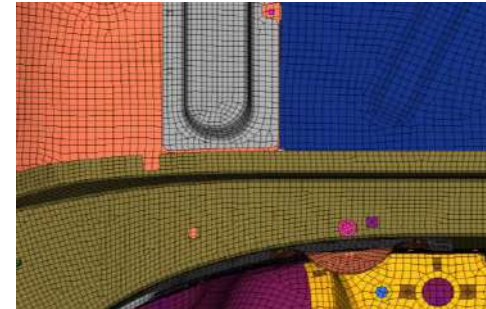
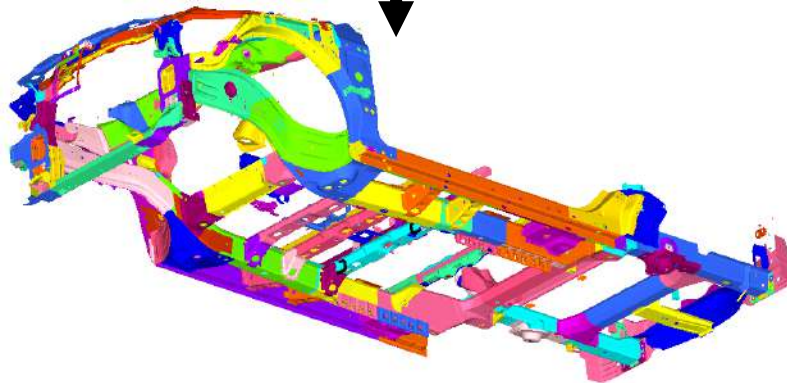



Smarter Solutions. Realized.

Detroit Engineered Products (DEP) is an Engineering Solutions and Product Development company. Since its inception in 1998 in Troy, Michigan, USA, DEP is now a global company with footprint in Europe, China, Korea, Japan and India. DEP uses the accelerated and transformed product development process, accomplished by utilizing our proprietary platform, DEP MeshWorks, which rapidly reduces the development time of products for all segments.

Rapid time to market of new products across several industry sectors such as automotive, defense, aerospace, energy, oil & gas, electronics, consumer products and heavy equipment is a unique value proposition delivered to clients via DEPs world class engineers and the DEP MeshWorks platform.



Email us: email@depusa.com | Visit our website: www.depusa.com

DEP LOCATIONS

USA

(Headquarters)
Detroit Engineered Products, Inc.
850 East Long Lake Road
Troy, Michigan 48085
Ph: +1 (248) 269 7130

INDIA

DEP India Pvt. Ltd.
#2/86, 7th Avenue,
Ashok Nagar, Chennai
600 083, India
Ph: +91 44 42141453

DEP India Pvt. Ltd.
4th Floor, Gamma Block,
Sigma Soft Tech Park,
HAL – Whitefield Main Rd
Bangalore 560066
Ph: +91 80 42052777

CANADA

1030 Cumming Blvd,
Milton, ON L9T 6S8,
Canada.

CHINA

DEP China software Co., Ltd.
Rm A2202, Building A, Vantone
Center, #333, Suhong Rd.,
Minhang District, Shanghai- 201106, China
Ph: +86-18665820511

JAPAN

DEP Japan Co., Ltd.
1129 the SOHO 2-7-4 Aomi
Koto-ku
Tokyo 135-0064
Japan
Ph: +81-3-4405-4868

BRAZIL

DEP Brazil Ltd.
Edifício Cabo Corporate Center
Rua 163, 226 – Sala 505
CEP – 54518-430
Cabo de Santo Agostinho
PE/Brasil
Ph: +55 (11) 5565 6612

PARTNER LOCATIONS

- FRANCE:** DynaS+, 5 Avenue Didier Daurat, 31400, Toulouse, France, Ph: +33 5 61 44 54 98 www.dynasplus.com
- GERMANY:** Dr, Schafstall Consultancy., Kiefernweg 3, 21357 Barum, Germany, Mobile: +49 160 8050767 Telephone: +49 4133 510410, hendrik@dr-schafstall-consultancy.com www.dr-schafstall-consultancy.com
- INDIA:** Spectratek, Animeesh., Plot No. 358, Lane Number 17, Mahatma Society, Pune, Maharashtra 411038, Ph: +91 9822052694 www.spectratek.co.in
- Suvidiscus, 54, Appanaickenpalayam, Thudiyalur, Coimbatore- 641017, Ph:+91 6385470666 www.suvidiscus.com
- ITALY:** Exemplar srl, Corso Vittorio Emanuele II, 161, 10139 Torino (Italy), Ph:+39 011435051 www.exemplar.com
- JAPAN:** IDAJ Co. Limited., 37F, Yokohama Landmark Tower, 2-2-1-1 Minato Mirai, Nishi-ku, Yokohama, Kanagawa, 220-8137, Japan, Ph: +81 45 683 1971 www.idaj.co.jp
- KOREA:** STC Integration Inc., #509, Yeongdongdaero 721, Gangnam, Seoul – 06072, Ph: +82 2 3446 9290
- SPAIN:** Simulexa., Carrer de Picanya, 39, Torrent, València, Spain, 46900 Ph: +34 96001823 www.simulexa.com
- THAILAND:** Sigma Solutions Co. Ltd., 77/95, Sinn Sathorn Tower, 23rd Floor, Thanon Krung Thon Buri, Khlong San, Bangkok 10600, Thailand. Ph: +662 862 1188 www.sigmasolutions.co.th
- TURKEY:** Bias Mühendislik Ltd. Sti., Haluk Turksoy sok. 12/3, Altunizade-Uskudar, 34662, Istanbul/Turkey, info@bias.com.tr, www.bias.com.tr
- USA:** MathPros, Inc., PO Box 102 Natick, MA 01760, support@mathpros.com, www.mathpros.com